

**SWISSDIS**



Swissdis AG  
Grasweg 7  
CH-4911 Schwarzhäusern

Tel.: +41 62 919 44 00  
Fax: +41 62 919 44 01  
[info@swissdis.ch](mailto:info@swissdis.ch)  
[www.swissdis.ch](http://www.swissdis.ch)



# SPECIFICATIONS

LED SMD PLCC2 sideview, White

**UPS008W**

Version June 2015

# Unilite Opto Technology

*email: info@unilite-tech.com*

## U-PS008-W-SD



### ■ Description

The PLCC2 type U-PS008W White Sideview LED, with its light weight , enables smaller board size, higher packing density, reduced storage space and miniature applications.

- Dice Material : InGaN
- Light Color : White
- Lens Color : Yellow

### ■ Features

- 1 chips package
- Compatible with automatic placement equipment
- Compatible with reflow soldering process
- Long operating life
- Low forward voltage operated
- Instant light
- Pb -free/ RoHS compliant
- 3000 pcs / Reel

### ■ Applications

- Information boards
- Automotive Interior Lighting
- Indoor and outdoor display
- Indicator
- Backlighting
- Light bar
- Gernal applications
- LED Light Bar

# Unilite Opto Technology

email: [info@unilite-tech.com](mailto:info@unilite-tech.com)

## U-PS008-W-SD

### ■ Outline Dimensions ( mm )

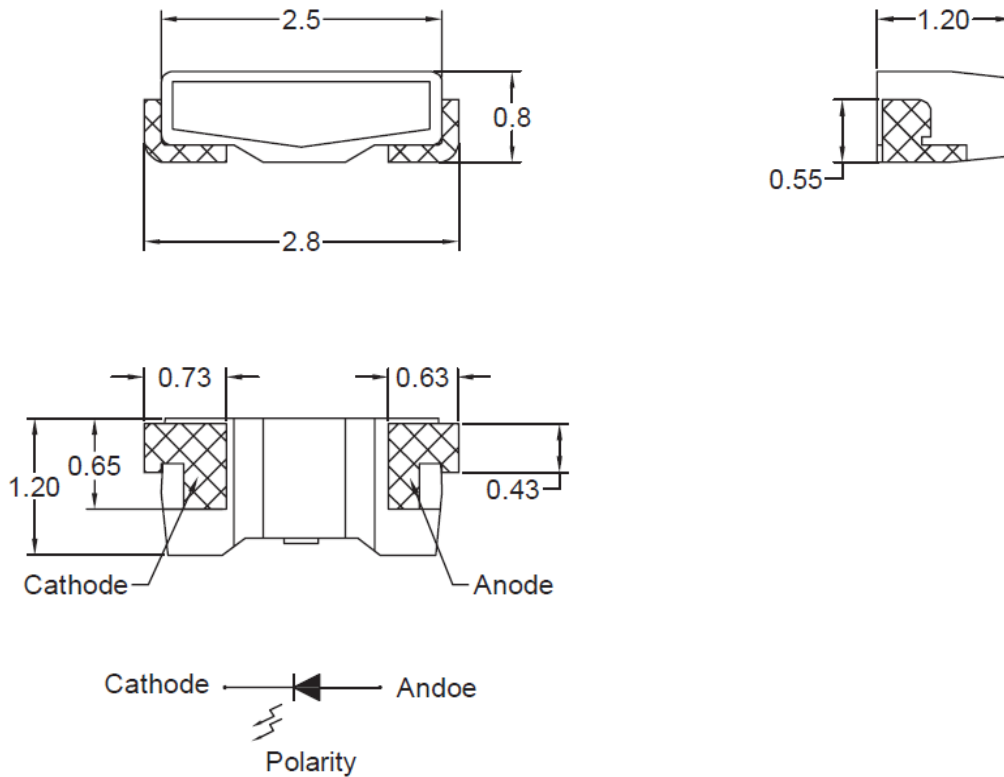

Tolerance :  $\pm 0.25$  mm

### ■ Recommend Soldering Pad ( mm )

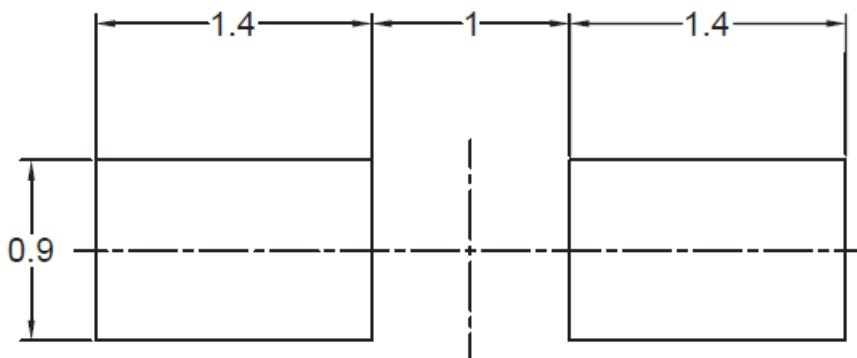

### ■ Part Numbering System

**U - P S 0 0 8 W - SD**

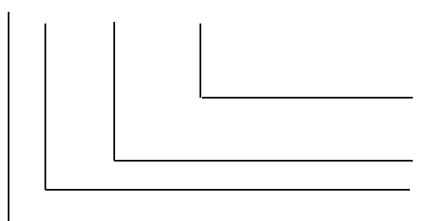

Color code: White

Package code: 008

Sideview

Product code

# Unilite Opto Technology

email: [info@unilite-tech.com](mailto:info@unilite-tech.com)

## U-PS008-W-SD

### ■ Absolute Maximum Ratings at Ta = 25 °C

PARAMETER	symbol	MAX.	UNIT
Power Dissipation *	PD	108	mW
Continuous Forward Current *	IF	30	mA
Peak Forward Current ( 1/10 Duty Cycle , 0.1ms Pulse Width ) *	IFP	100	mA
Reverse Voltage	VR	5	V
Electrostatic Discharge	ESD	500	V
Operating Temperature Range	Topr	-20 to + 80	°C
Storage Temperature Range	Tstg	-30 to + 100	°C
Reflow Soldering Condition	Tsld	260 °C for 10 sec. 2 time.	

### ■ Electro-Optical Characteristics

Condition :  $I_F = 20\text{mA}$  ,  $T_a = 25^\circ\text{C}$

PARAMETER	SYMBOL	TEST CONDITION	VALUES			UNIT
			MIN.	TYP.	MAX.	
* Forward Voltage	$V_F$	$I_F=20\text{mA}$	2.8		3.4	V
Chromaticity Corrdinates	X	$I_F=20\text{mA}$	0.257		0.288	
	Y	$I_F=20\text{mA}$	0.323		0.281	
Luminous Intensity	lm	$I_F=20\text{mA}$	1700	1800	2000	mcd
Viewing Angle at 50% Iv	$2\theta$ 1/2	$I_F=20\text{mA}$		115		Deg.

# Unilite Opto Technology

email: [info@unilite-tech.com](mailto:info@unilite-tech.com)

## U-PS008-W-SD

■ Bin Grade Limits ( $I_F = 20 \text{ mA}^*$ ) Luminous Intensity / mcd

Tolerance :  $\pm 15\%$

Bin	X25X31	X32X33	X34X35	X36X37	X11X12
Min.	1600	1700	1800	1900	2000
Max.	1700	1800	1900	2000	2100

■ Bin Grade Limits ( $I_F = 20 \text{ mA}^*$ ) Forward Voltage

Bin Code	Min	Max	Unit
V26	2.6	2.8	V
V28	2.8	3.0	V
V30	3.0	3.2	V
V32	3.2	3.4	V
V33	3.4	3.6	V
V34	3.6	3.8	V

# Unilite Opto Technology

email: [info@unilite-tech.com](mailto:info@unilite-tech.com)

## U-PS008-W-SD

### ■ Chromaticity Corrdinates Specification for Bin Grades

Bin code	Kelvin	1		2		3		4	
		X	Y	X	Y	X	Y	X	Y
A31	10000-14000K	0.264	0.267	0.272	0.258	0.282	0.272	0.28	0.281
A32	10000-14000K	0.272	0.258	0.280	0.248	0.288	0.262	0.28	0.272
A23	14000-20000K	0.265	0.244	0.257	0.253	0.264	0.267	0.27	0.258
A24	14000-20000K	0.274	0.232	0.265	0.244	0.272	0.258	0.280	0.248

### ■ CIE Chromaticity Diagram

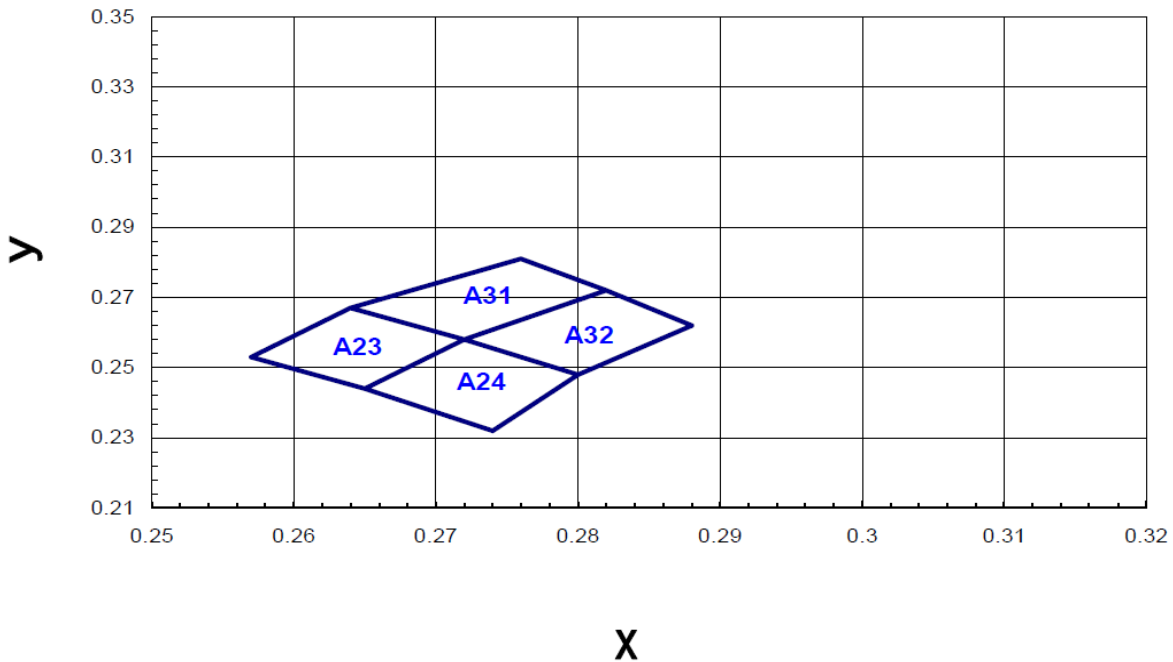

# Unilite Opto Technology

email: [info@unilite-tech.com](mailto:info@unilite-tech.com)

## U-PS008-W-SD

### ■ Typical Electro-Optical Characteristics Curve

Fig.1 Forward current vs. Forward Voltage

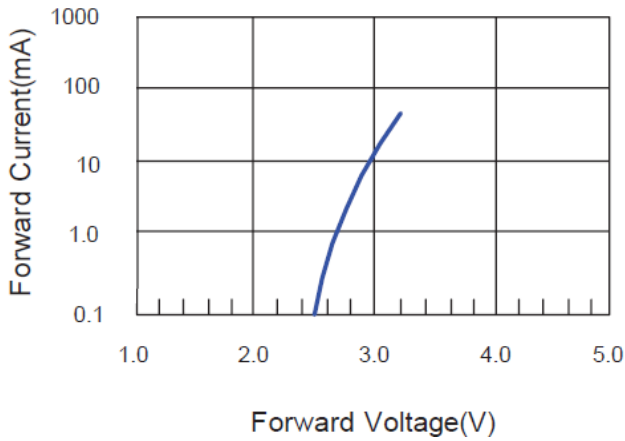

Fig.2 Relative Intensity vs. Forward Current

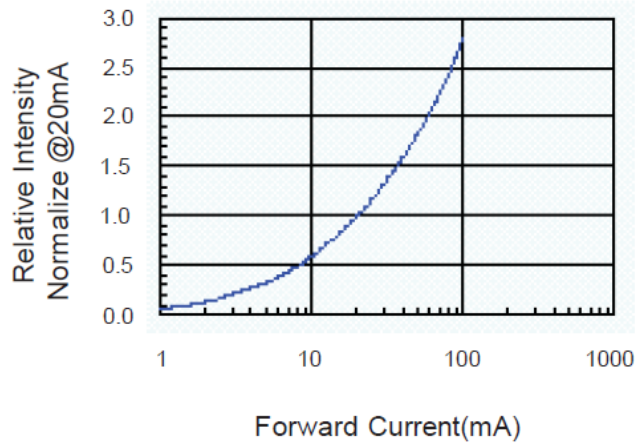

Fig.3 Forward Voltage vs. Temperature

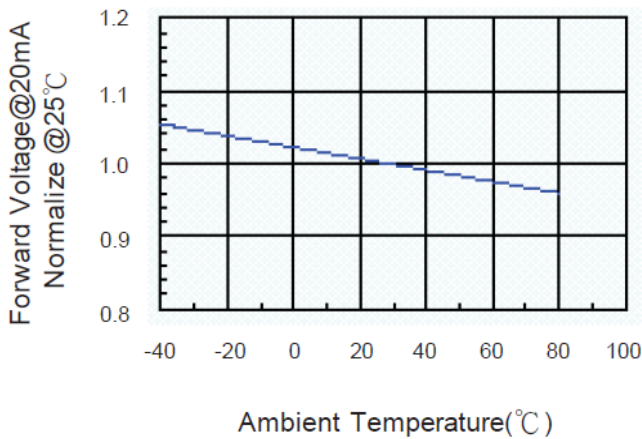

Fig.4 Relative Intensity vs. Temperature

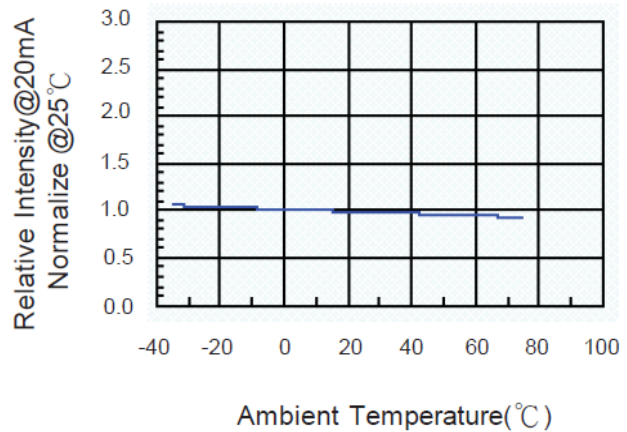

Fig.5 Luminous Spectrum (Ta=25°C)

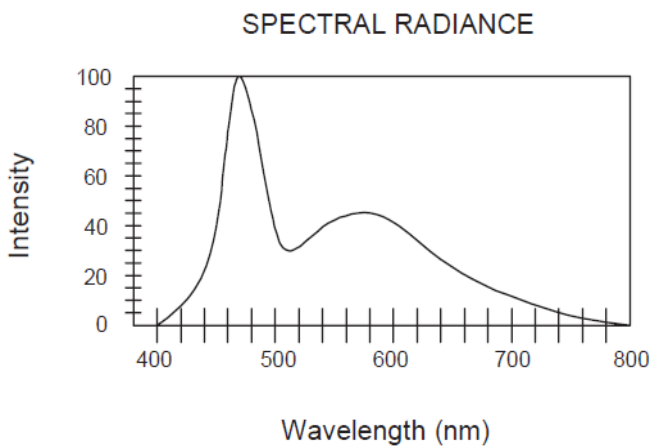
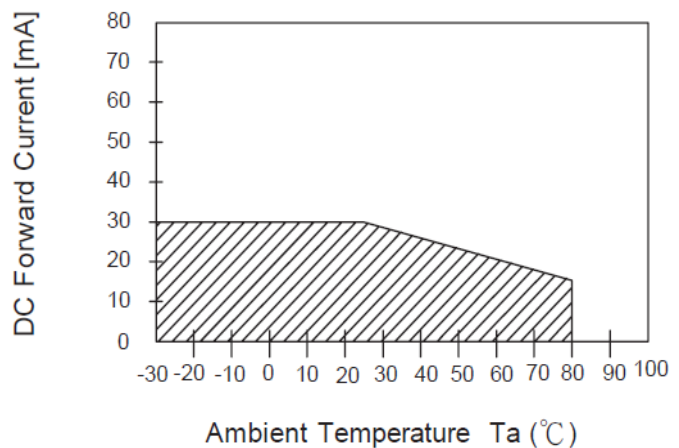

Fig.6 Forward Current vs. Temperature



# Unilite Opto Technology

email: [info@unilite-tech.com](mailto:info@unilite-tech.com)

## U-PS008-W-SD

### ■ Carrier Type Dimensions

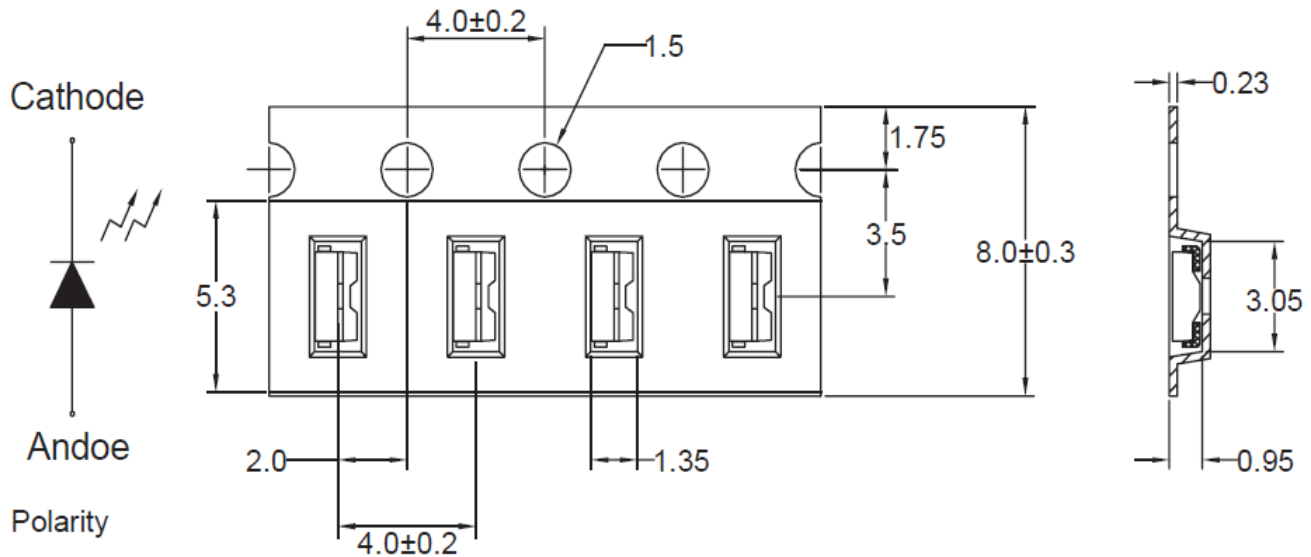

### ■ Reel Dimensions

Q'ty : 3000pcs / Reel

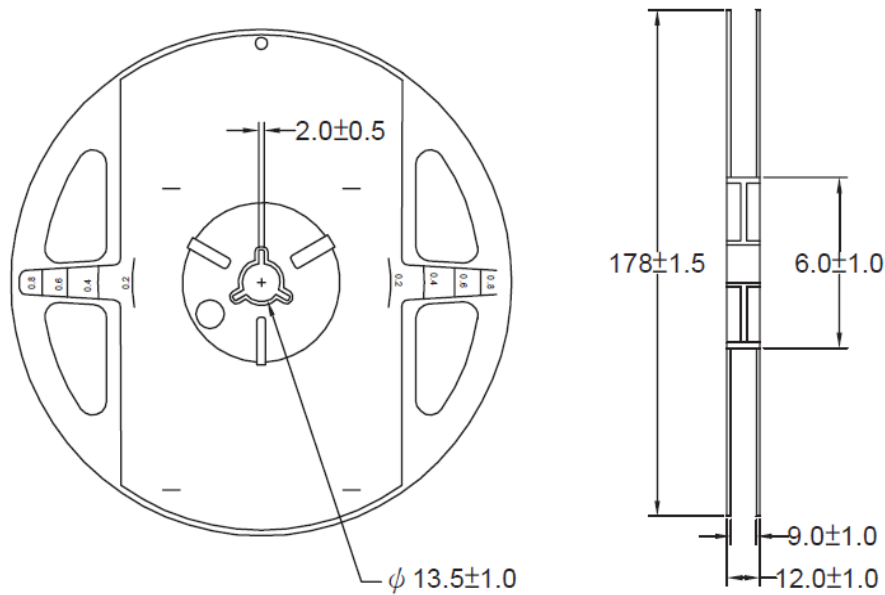



# Unilite Opto Technology

*email: info@unilite-tech.com*

## U-PS008-W-SD

### ■ Cautions

#### (1) Moisture Proof Package

- A) The moisture proof package, a plastic bag with a zipper, is used to keep moisture to a minimum in the package.
- B) A package of a moisture absorbent material (silica gel) is also inserted into the plastic moisture proof bag and the silica gel changes its color from blue to pink as it absorbs moisture.
- C) The absorbed moisture in the SMT package may vaporize and expand during soldering. This may cause exfoliation of the contacts and damage to the optical characteristics of the LEDs.

#### (2) Storage Conditions

- A) Before opening the package :  
The LEDs should be kept at 30°C or less and 45~60% RH or less and should be used within a year. When storing the LEDs, moisture proof package with absorbent material (silica gel) is recommended.
- B) After opening the package :  
The LEDs should be kept at 30°C or less and 55% RH or less and should be soldered within 168 hours (7days) after opening the package. The unused LEDs should be stored in moisture proof packages.
- C) It's also recommended to return the LEDs to the original moisture proof bag and to reseal the moisture proof bag again.
- D) If the moisture absorbent material (silica gel) has faded away or the SMD LEDs have exceeded the storage time, baking treatment ( more than 24 hours at 65+/-5°C) should be performed before soldering.

#### (3) Heat Generation

- A) The thermal design of the end product is very important. It is necessary to avoid intense heat generation and operate within the maximum ratings given in this specification.
- B) The operating current should be decided after considering the ambient maximum temperature of LEDs.

#### (4) Cleaning

- A) Isopropyl alcohol is recommended to be used as a solvent for cleaning the LEDs.
- B) Before cleaning, a pre-test should be done to confirm whether any damage to the LEDs will occur.

# Unilite Opto Technology

email: [info@unilite-tech.com](mailto:info@unilite-tech.com)

## U-PS008-W-SD

### (5) Soldering

Reflow Soldering ( recommended ) :

- A) To prevent from cracking, please bake ( 65°C , 24hrs ) before soldering.
- B) When soldering, do not load stress on the LEDs during heating.
- C) Never take next process until the component is cooled down to room temperature after reflow.
- D) After soldering, do not warp the circuit board.
- E) The recommended reflow soldering profile ( measuring on the surface of the LED resin ) is the following:

#### (a) Lead-Free Solder

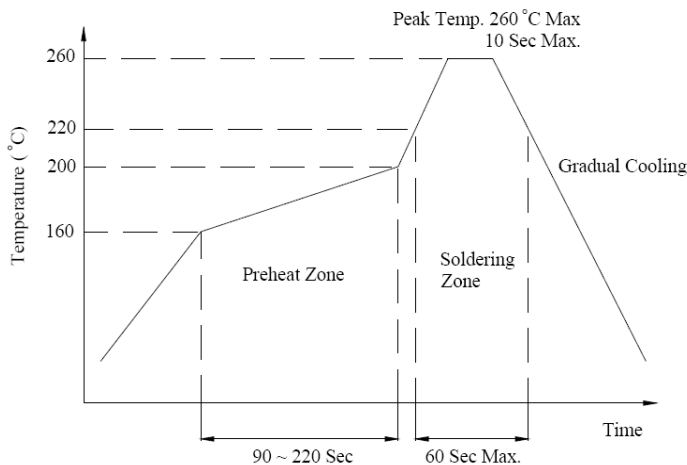

#### (b) Lead Solder

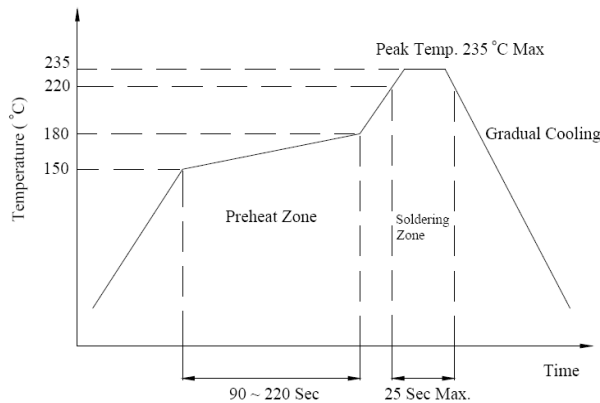

Manual Soldering ( not recommended ) :

- A) To prevent from cracking, please bake ( 65°C , 24hrs ) before soldering.
- B) Temperature at tip of iron: 250°C Max. ( 25W ).
- C) It's banned to load any stress on the resin during soldering.
- D) Soldering time: 3 sec. Max.( one time only ).

# Unilite Opto Technology

*email: info@unilite-tech.com*

## U-PS008-W-SD

- (6) ESD ( eletrostatic discharge ) protection ( base on machine mode )
- A) The product is Gallium InGaN based light emitting diode ( LED ) and is extremely sensitive to ESD. Users are strongly recommended to take necessary meter to test the static electricity and avoid ESD when handling this product.
  - B) Proper grounding of machines ( via  $1M\Omega$  ), using static dissipative mats, containers, working uniforms and shoes are considered to be effective against ESD.
  - C) An ionizer is recommended in the facility or environment where ESD may be generated easily, and soldering iron with a grounded tip is also recommended.
  - D) When inspecting the final products in which LEDs are assembled, it is recommended to check whether the assembled LEDs are damaged by ESD or not. It is simple to find damaged LEDs by light-on or VF test at lower current ( below 1mA is recommended ).
  - E) ESD damaged LEDs will show some unusual characteristics such as the remarkable increasing of leak current, the decreasing of forward voltage, or the LEDs do not light on at the low current.
- (7) Other
- A) Care must be taken to ensure that the reverse voltage will not exceed the absolute maximum rating when using the LEDs with matrix drive.
  - B) The LED light output is strong enough to injure human eyes. Precaution must be taken to prevent looking directly at the LEDs with unaided eyes for more than a few seconds.
  - C) The LEDs described here are intended to be used for ordinary electronic equipment, please consult Unilite Opto in advance for information on applications.
  - D) Installing a protection device in the LED driving circuit to avoid surge current exceeding the max rating during on/off switching.
  - E) The appearance and specifications of the product may be modified for improvement without notice.
  - F) Please use the product within 168 hours after opening the seal and keep under  $30\text{ }^{\circ}\text{C}$  and 70% humidity.
  - G) Unilite Opto Technology will not be responsible for any claim for damage if the user use the product without following the caution or instruction of the specification.

# Unilite Opto Technology

email: [info@unilite-tech.com](mailto:info@unilite-tech.com)

## U-PS008-W-SD

### ■ Handling Precautions

(1) Compare to epoxy encapsulant that is hard and brittle, silicone is softer and flexible. Although its characteristic significantly reduces thermal stress, it is more prone to damage by external mechanical force. As a result, special handling precautions must be observed during assembling using silicone encapsulated LED products, failure to comply might leads to damage and premature failure of the LED.

- A) Pick up the component along the side surface by using forces or appropriate tools. Do not directly touch or pick the silicone lens surface as it could cause the damage the internal circuit.

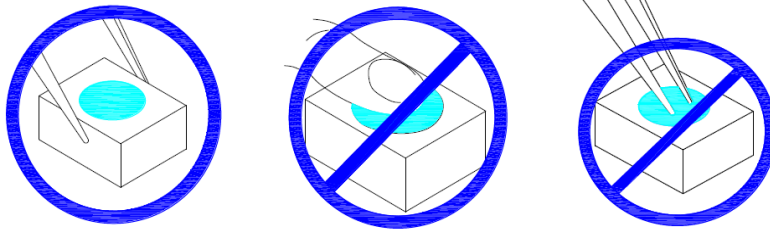

- B) The outer diameter of the SMD pickup nozzle should not exceed the size of the LED in order to prevent from the air leaking. The inner diameter of the nozzle should be as large as possible. A pliable material is suggested that the nozzle tip to avoid scratching or damaging of the LED surface during pickup. The dimensions of the component must be accurately programmed in the pick-and-place machine to insure precise pickup and avoid damage during production.



- C) Do not stack the assembled PCB with LED together. The impact could scratch the silicone lens or damage the internal circuit.

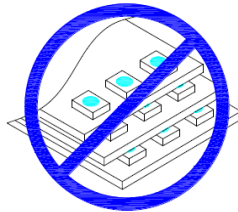

- D) Not suitable to operate in acidic environment, PH<7

