

SWISSDIS



Swissdis AG
Grasweg 7
CH-4911 Schwarzhäusern

Tel.: +41 62 919 44 00
Fax: +41 62 919 44 01
info@swissdis.ch
www.swissdis.ch



SPECIFICATIONS

Wire Wound Chip Inductor (Ferrite)

NLV-Serie

Version May 2013

Wire Wound Chip Inductor (Ferrite)

■ Features

- Very strong solderability by flow soldering, soldering iron or wave soldering
- Highly accurate dimensions, can be mounted automatically
- Terminals are highly resistant to pull forces
- Highly resistant to mechanical shocks and pressure
- Highly reliable in environments of sudden temperature change and humidity.
- Super Q characteristics

■ Applications

- Micro Televisions, Liquid Crystal Televisions, Video Cameras, Portable VCRs, Car Radios, Car Stereos, Thin Tape Radios, Television Tuners, Mobile Telephones, Radio and Other Electronic Devices

■ Construction

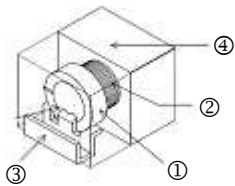

① Ferrite core	③ Electrode (Tinned Copper Wire)
② Polyurethane wire	④ Thermoplastic resin

■ Part Numbering

NLV	08	M	T	C	1R0
Product Type	Dimensions (LxW)	Inductance Tolerance	Packaging Code	Current	Inductance
	08: 1008 10: 1210	J: ±5% K: ±10% M: ±20%	T: Taping Reel	: Standard C: Large Current	10N: 10nH R27: 270nH 2R7: 2700nH 100: 10µH

Wire Wound Chip Inductor (Ferrite)

■ Dimensions

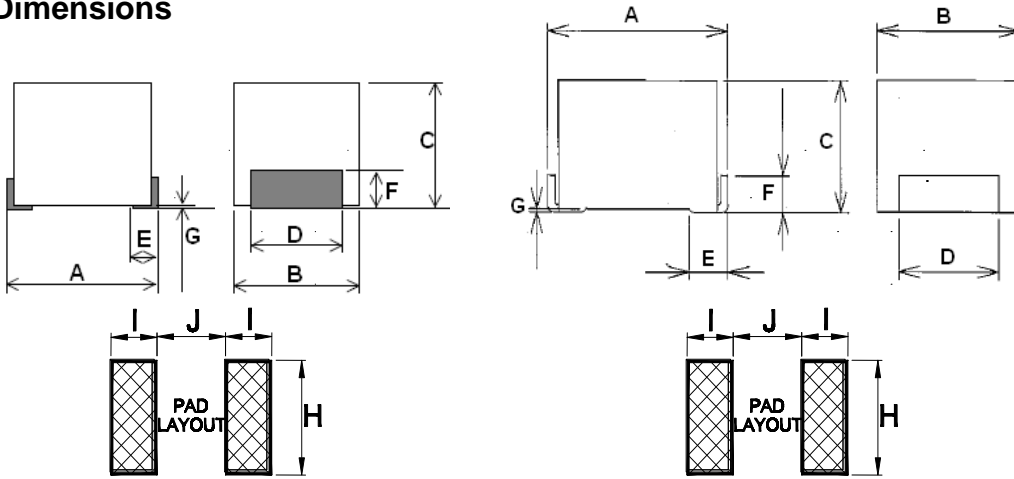

Figure 1

Figure 2

Unit: mm

Type	Size (Inch)	Figure	A	B	C	D	E	F	G	H	I	J
NLV08	1008	1	2.5±0.2	2.0±0.1	1.8±0.1	1.4±0.1	0.4	0.5	0.01~0.1	1.5	1.0	1.5
NLV10	1210	1	3.2±0.2	2.5±0.2	2.2±0.2	1.9±0.1	0.4	0.5	0.01~0.1	2.0	1.2	2.0
NLV08(C)	1008	2	2.5±0.2	2.0±0.1	1.8±0.1	1.4±0.1	0.4	0.5	0.01~0.1	1.5	1.0	1.5
NLV10(C)	1210	1	3.2±0.2	2.5±0.2	2.2±0.2	1.9±0.1	0.4	0.5	0.01~0.1	2.0	1.2	2.0

■ Standard Electrical Specifications

NLV08 Wire Wound Chip Inductors (Ferrite / Molding Type) / Standard Type

Codes	Inductance (μH)	Tolerance	Q min.	Test Freq. (MHz)	SRF (MHz) min.	DCR (Ω) max.	IDC (mA) max.
10N	0.010	±5%	15	100	2150	0.26	530
12N	0.012	±5%	15	100	2050	0.27	500
15N	0.015	±5%	15	100	2000	0.29	480
18N	0.018	±5%	15	100	1850	0.31	450
22N	0.022	±5%	15	100	1650	0.37	420
27N	0.027	±5%	15	100	1550	0.40	410
33N	0.033	±5%	20	100	1450	0.42	400
39N	0.039	±5%	20	100	1350	0.45	380
47N	0.047	±5%	20	100	1200	0.50	360
56N	0.056	±5%	20	100	1100	0.60	340
68N	0.068	±5%	20	100	1050	0.65	320
82N	0.082	±5%	20	100	900	0.75	300
R10	0.10	±5%	20	100	800	0.80	280
R12	0.12	±5%	30	25.2	700	0.30	550
R15	0.15	±5%	30	25.2	550	0.35	500
R18	0.18	±5%	30	25.2	500	0.40	475
R22	0.22	±5%	30	25.2	450	0.50	450
R27	0.27	±5%	30	25.2	425	0.55	425
R33	0.33	±5%	30	25.2	400	0.60	400
R39	0.39	±5%	30	25.2	375	0.65	375
R47	0.47	±5%	30	25.2	350	0.68	350
R56	0.56	±5%	30	25.2	325	0.75	325
R68	0.68	±5%	30	25.2	300	0.85	300
R82	0.82	±5%	30	25.2	260	1.00	260

Wire Wound Chip Inductor (Ferrite)

NLV08 Wire Wound Chip Inductors (Ferrite / Molding Type) / Standard Type

Codes	Inductance (μH)	Tolerance	Q min.	Test Freq. (MHz)	SRF (MHz) min.	DCR (Ω) max.	IDC (mA) max.
1R0	1.0	±5%	30	7.96	245	1.10	245
1R2	1.2	±5%	30	7.96	230	1.20	230
1R5	1.5	±5%	30	7.96	182	1.30	220
1R8	1.8	±5%	30	7.96	135	1.45	210
2R2	2.2	±5%	30	7.96	105	1.55	200
2R7	2.7	±5%	30	7.96	70	1.70	195
3R3	3.3	±5%	30	7.96	55	1.90	185
3R9	3.9	±5%	30	7.96	48	2.10	180
4R7	4.7	±5%	30	7.96	43	2.30	175
5R6	5.6	±5%	25	7.96	42	2.50	170
6R8	6.8	±5%	25	7.96	39	2.70	165
8R2	8.2	±5%	25	7.96	36	3.05	160
100	10	±5%	25	2.52	33	3.50	155
120	12	±5%	25	2.52	30	3.80	150
150	15	±5%	25	2.52	26	4.40	140
180	18	±5%	25	2.52	24	4.80	130
220	22	±5%	25	2.52	22	5.50	125
270	27	±5%	25	2.52	21	6.30	115
330	33	±5%	25	2.52	20	7.10	110
390	39	±5%	20	2.52	18	9.50	90
470	47	±5%	20	2.52	17	11.10	80
560	56	±5%	20	2.52	16	12.10	75
680	68	±5%	20	2.52	15	16.60	70
820	82	±5%	20	2.52	13	19.00	66
101	100	±5%	15	0.796	12	21.00	60

■ Operating Temperature Range: -40~+105°C

NLV10 Wire Wound Chip Inductors (Ferrite / Molding Type) / Standard Type

Codes	Inductance (μH)	Tolerance	Q min.	Test Freq. (MHz)	SRF (MHz) min.	DCR (Ω) max.	IDC (mA) max.
10N	0.010	±5%	15	100	2500	0.13	450
12N	0.012	±5%	17	100	2300	0.14	450
15N	0.015	±5%	19	100	2100	0.16	450
18N	0.018	±5%	21	100	1900	0.18	450
22N	0.022	±5%	23	100	1700	0.20	450
27N	0.027	±5%	23	100	1500	0.22	450
33N	0.033	±5%	25	100	1400	0.24	450
39N	0.039	±5%	25	100	1300	0.27	450
47N	0.047	±5%	26	100	1200	0.30	450
56N	0.056	±5%	26	100	1100	0.33	450
68N	0.068	±5%	27	100	1000	0.36	450
82N	0.082	±5%	27	100	900	0.40	450
R10	0.10	±5%	28	100	700	0.44	450
R12	0.12	±5%	30	25.2	500	0.22	450
R15	0.15	±5%	30	25.2	450	0.25	450
R18	0.18	±5%	30	25.2	400	0.28	450
R22	0.22	±5%	30	25.2	350	0.32	450
R27	0.27	±5%	30	25.2	320	0.36	450
R33	0.33	±5%	30	25.2	300	0.40	450
R39	0.39	±5%	30	25.2	250	0.45	450

Wire Wound Chip Inductor (Ferrite)

NLV10 Wire Wound Chip Inductors (Ferrite / Molding Type) / Standard Type

Codes	Inductance (μH)	Tolerance	Q min.	Test Freq. (MHz)	SRF (MHz) min.	DCR (Ω) max.	IDC (mA) max.
R47	0.47	±5%	30	25.2	220	0.50	450
R56	0.56	±5%	30	25.2	180	0.55	450
R68	0.68	±5%	30	25.2	160	0.60	450
R82	0.82	±5%	30	25.2	140	0.65	450
1R0	1.0	±5%	30	7.96	120	0.70	400
1R2	1.2	±5%	30	7.96	100	0.75	390
1R5	1.5	±5%	30	7.96	85	0.85	370
1R8	1.8	±5%	30	7.96	80	0.90	350
2R2	2.2	±5%	30	7.96	75	1.00	320
2R7	2.7	±5%	30	7.96	70	1.10	290
3R3	3.3	±5%	30	7.96	60	1.20	260
3R9	3.9	±5%	30	7.96	55	1.30	250
4R7	4.7	±5%	30	7.96	50	1.50	220
5R6	5.6	±5%	30	7.96	45	1.60	200
6R8	6.8	±5%	30	7.96	40	1.80	180
8R2	8.2	±5%	30	7.96	35	2.00	170
100	10	±5%	30	2.52	30	2.10	150
120	12	±5%	30	2.52	20	2.50	140
150	15	±5%	30	2.52	20	2.80	130
180	18	±5%	30	2.52	20	3.30	120
220	22	±5%	30	2.52	20	3.70	110
270	27	±5%	30	2.52	20	5.00	80
330	33	±5%	30	2.52	17	5.60	70
390	39	±5%	30	2.52	16	6.40	65
470	47	±5%	30	2.52	15	7.00	60
560	56	±5%	30	2.52	13	8.00	55
680	68	±5%	30	2.52	12	9.00	50
820	82	±5%	30	2.52	11	10.00	45
101	100	±5%	20	0.796	10	10.00	40
121	120	±5%	20	0.796	10	11.00	70
151	150	±5%	20	0.796	8	15.00	65
181	180	±5%	20	0.796	7	17.00	60
221	220	±5%	20	0.796	7	21.00	50
271	270	±5%	20	0.796	6	28.00	45
331	330	±5%	20	0.796	5	34.00	40
391	390	±5%	20	0.796	5	36.00	35
471	470	±5%	20	0.796	4	40.00	25

■ Operating Temperature Range: -40~+105°C

Large Current Electrical Specifications

NLV08 Wire Wound Chip Inductors (Ferrite / Molding Type) / **Large Current Type**

Codes	Inductance (μH)	Tolerance	Q ref.	Test Freq. (MHz)	SRF (MHz) min.	DCR (Ω) ±30%.	IDC (mA) max.
1R0	1.0	±20%	20	7.96	200	0.34	475
1R5	1.5	±20%	20	7.96	165	0.42	435
2R2	2.2	±20%	20	7.96	95	0.50	390
3R3	3.3	±20%	20	7.96	55	0.65	340
4R7	4.7	±20%	20	7.96	43	0.80	285
6R8	6.8	±20%	20	7.96	39	1.00	275
100	10	±10%	30	2.52	32	1.69	210
150	15	±10%	30	2.52	21	2.20	175
220	22	±10%	30	2.52	18	2.80	160
330	33	±10%	30	2.52	16	4.20	120

■ Operating Temperature Range: -40~+85°C

NLV10 Wire Wound Chip Inductors (Ferrite / Molding Type) / **Large Current Type**

Codes	Inductance (μH)	Tolerance	Q ref.	Test Freq. (MHz)	SRF (MHz) min.	DCR (Ω) ±30%.	IDC (mA) max.
1R0	1.0	±20%	10	7.96	100	0.06	1000
1R5	1.5	±20%	10	7.96	80	0.11	830
2R2	2.2	±20%	10	7.96	68	0.13	770
3R3	3.3	±20%	10	7.96	54	0.16	690
4R7	4.7	±20%	15	7.96	46	0.20	620
6R8	6.8	±20%	15	7.96	38	0.27	530
100	10	±10%	15	2.52	30	0.36	450
150	15	±10%	15	2.52	26	0.56	370
220	22	±10%	15	2.52	21	0.77	300
330	33	±10%	15	2.52	17	1.10	240
470	47	±10%	15	2.52	14	1.64	180
680	68	±10%	15	2.52	12	2.80	140
101	100	±10%	15	0.796	10	3.70	120
151	150	±10%	20	0.796	8	6.10	100
221	220	±10%	20	0.796	7	8.40	80
331	330	±10%	20	0.796	6	12.30	70

■ Operating Temperature Range: -40~+105°C

Environmental Characteristics

Electrical Performance Test

Item	Requirement	Test Method
Inductance	Refer to standard electrical characteristic spec.	HP4291
Q		HP4291
SRF		HP4291
DC Resistance DCR		Agilent 34401A
Rated Current IDC		Applied the current to coils, The inductance change should be less than 10% to initial value

Mechanical Performance Test

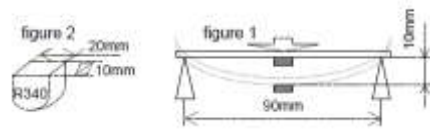
Item	Requirement	Test Method
Solderability	The electrodes shall be at least 90% covered with new solder coating	Lead-free inductor: after fluxing(alpha 100 or equiv), inductor shall be dipped in a melted solder bath at 230±5°C, 5±0.5 seconds
Resistance to Soldering Heat	Appearance: No mechanical damage L change: within±5%	Pre-heating: 150°C, 1min. Solder Temperature: 260±5°C Immersion Time: 10±1 seconds
Vibration	Appearance: No mechanical damage L change: within±3%	The sample shall be soldered onto the PCB, then the vibration having the frequency of 10 to 55Hz/min. and amplitude of 1.52mm Should be applied
Lead Tensile Strength	There should be no abnormality	A tensile rod of 4.9N is applied horizontally to both leads of the sample
Flexibility		The sample shall be soldered onto PCB as shown in figure 1 and a load applied until the flexure in the arrow direction is made almost 10mm (figure 2 it used). Then it should be returned to its Original position. Then this operation should be repeated 5 times 
Drop	Appearance: No mechanical damage L change: within±3%	The sample shall be dropped once naturally onto a concrete floor from a height of 1 meter
Insulation Resistance	More than 1X10 ⁸ Ω	DC 250V voltage shall be applied for 30 seconds across the band and the leads
Dielectric Withstanding Voltage	There should be no abnormality	AC 100V voltage shall be applied for 1 minute across the body and the leads

Climatic Test

Item	Requirement	Test Method
Temperature Cycle	Appearance: No mechanical damage L change: within±5%	For NLV08/NLV10/NLV10C Series : The sample should be soldered onto the PCB, then it shall be left into 100 cycles of temperature cycling for -40°C~105°C,30 minutes each as For NLV08C Series: The sample should be soldered onto the PCB, then it shall be left into 100 cycles of temperature cycling for -40°C~85°C,30 minutes each as Measured after exposure in the room condition for 24 hrs
Moisture Storage	Appearance: No mechanical damage L change: within±5% Q change: within±30%	Temperature: 60±2°C Relative Humidity: 90 ~ 95% Time: 1000 hrs Measured after exposure in the room condition for 24 hrs
High Temperature Storage	Appearance: No mechanical damage L change: within±5% Q change: within±30%	For NLV08/NLV10/NLV10C Series : Temperature: 105±2°C, Time: 1000 hrs For NLV08C Series: Temperature: 85±2°C, Time: 1000 hrs Measured after exposure in the room condition for 24 hrs
Low Temperature Storage	Appearance: No mechanical damage L change: within±5% Q change: within±20%	Temperature: -40±2°C Time: 1000 hrs Measured after exposure in the room condition for 24 hrs

■ Storage Temperature: 25±3°C; Humidity < 80%RH

■ Packaging

Packaging Quantity & Reel Specifications

Type	ΦA	ΦB	ΦC	W	T	Quantity (EA)
NLV08	178±2.0	60±0.5	13±0.3	9±0.3	12±1.0	2000
NLV10	178±2.0	60±0.5	13±0.3	9±0.3	12±1.0	2000

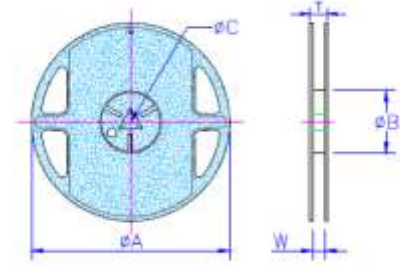

Embossed Plastic Tape Specifications

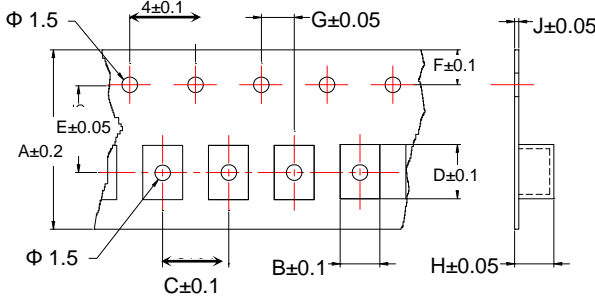

Unit: mm

Type	A	B	C	D	E	F	G	H	J
NLV08	8	2.3	4.0	2.7	3.5	1.75	2.0	2.0	0.4
NLV10	8	2.8	4.0	3.5	3.5	1.75	2.0	2.3	0.4

Leader / Trailer Tape

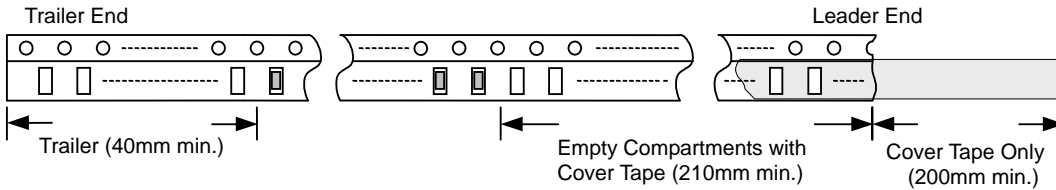

Cover Tape Peel Strength

The force for tearing off cover tape is 0.1~0.7 (N) in the arrow direction at the following conditions:

Temperature: 5~35℃

Humidity: 45~85%

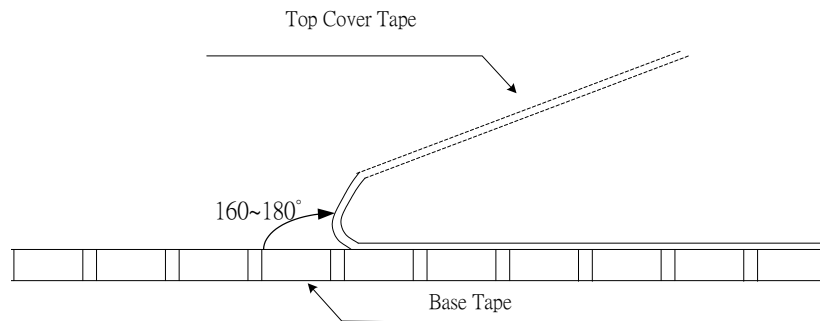

■ Soldering Conditions

