

**SWISSDIS**



Swissdis AG  
Grasweg 7  
CH-4911 Schwarzhäusern

Tel.: +41 62 919 44 00  
Fax: +41 62 919 44 01  
[info@swissdis.ch](mailto:info@swissdis.ch)  
[www.swissdis.ch](http://www.swissdis.ch)



# SPECIFICATIONS

Multilayer Chip Bead

**CBM-Serie**

Version August 2016

## Multilayer Chip Beads



### ■ Features

- Effective EMI protection
- Low DC resistance
- High soldering heat resistance
- Multiple size availability

### ■ Applications

- Computers and Peripheral Equipment
- VCRS, Television, Pagers
- Cellular Phones
- Digital Communication Equipment
- Various Electronics Equipments
- Circuit Where a Stable Ground is Unavailable

### ■ Construction

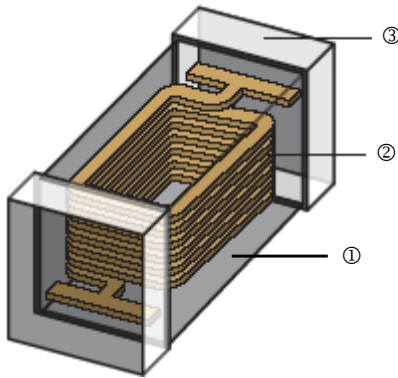

① Ferrite	② Internal Electrode	③ Electrode Plating
-----------	----------------------	---------------------

### ■ Dimensions

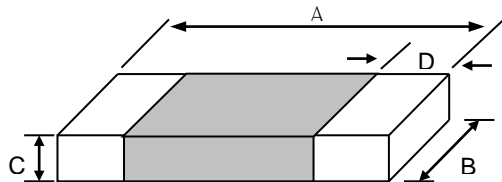

Unit : mm

Type	Size (Inch)	A	B	C	D	Weight (g) (1000pcs)
CBM01	0201	0.6±0.03	0.30±0.03	0.30±0.03	0.1~0.2	1.1
CBM02	0402	1.0±0.10	0.50±0.10	0.5±0.10	0.1~0.35	2.6
CBM03	0603	1.6±0.20	0.80±0.15	0.8±0.15	0.1~0.6	6.2
CBM05	0805	2.0±0.20	1.25±0.20	0.9±0.20	0.2~0.8	10
CBM04	1204	3.2±0.20	1.60±0.20	1.1±0.20	0.2~1.0	30
CBM10	1210	3.2±0.20	2.50±0.20	1.3±0.20	0.2~1.0	54
CBM08	1808	4.5±0.25	1.60±0.20	1.6±0.20	0.2~1.0	60
CBM12	1812	4.5±0.25	3.20±0.20	1.5±0.20	0.2~1.0	62
CBM20(170Ω)	2220	5.59±0.51	5.08±0.25	1.52±0.25	0.51~1.01	62
CBM20(150Ω)	2220	5.59±0.51	5.08±0.25	1.80±0.25	0.51~1.01	62
CBM20(600Ω)	2220	5.59±0.51	5.08±0.25	3.05±0.25	0.51~1.01	62

**Multilayer Chip Beads**

**■ Part Numbering**

<b>CBM</b>	<b>03</b>	<b>Y</b>	<b>T</b>	<b>A</b>	<b>N</b>	<b>601</b>
Product Type	Dimensions	Impedance Tolerance	Packaging Code	Material Code	Current	Impedance
	01: 0201 02: 0402 03: 0603 05: 0805 04: 1204 10: 1210 08: 1808 12: 1812 20: 2220	Y: ±25%	T: Taping Reel	A: A material B: B material H: H material K: K material I: i material	H: High current G: Medium current N: General current F: High Frequency C: High current & High Frequency	090: 9Ω 110: 11Ω 451: 450Ω 152: 1500Ω

**■ Standard Electrical Specifications(for General Signal Line Use)**

CBM01(060303) / A Material

Part No.	Impedance (Ω)	Tolerance	Test Freq. (MHz)	DCR (Ω) max	Rated Current (mA) max
CBM01YTAN100	10	±25%	100	0.10	500
CBM01YTAN300	30	±25%	100	0.30	300
CBM01YTAN400	40	±25%	100	0.30	300
CBM01YTAN500	50	±25%	100	0.30	300
CBM01YTAN600	60	±25%	100	0.35	300
CBM01YTAN700	70	±25%	100	0.35	300
CBM01YTAN121	120	±25%	100	0.45	200
CBM01YTAN151	150	±25%	100	0.50	200
CBM01YTAN221	220	±25%	100	0.75	200
CBM01YTAN301	300	±25%	100	0.90	150

CBM02(100505) / A Material

Part No.	Impedance (Ω)	Tolerance	Test Freq. (MHz)	DCR (Ω) max.	Rated Current (mA) max.
CBM02YTAN100	10	±25%	100	0.05	500
CBM02YTAN300	30	±25%	100	0.20	300
CBM02YTAN400	40	±25%	100	0.20	300
CBM02YTAN600	60	±25%	100	0.40	200
CBM02YTAN700	70	±25%	100	0.40	200
CBM02YTAN800	80	±25%	100	0.40	200
CBM02YTAN101	100	±25%	100	0.45	200
CBM02YTAN121	120	±25%	100	0.50	200
CBM02YTAN121-1	120	±25%	100	0.20	500
CBM02YTAN151	150	±25%	100	0.60	200
CBM02YTAN181	180	±25%	100	0.65	100
CBM02YTAN221	220	±25%	100	0.70	100
CBM02YTAN221-1	220	±25%	100	0.28	700
CBM02YTAN221-3	220	±25%	100	0.35	300
CBM02YTAN301	300	±25%	100	0.75	100
CBM02YTAN301-1	300	±25%	100	0.45	400
CBM02YTAN331	330	±25%	100	0.75	100
CBM02YTAN471	470	±25%	100	0.90	100
CBM02YTAN501	500	±25%	100	1.00	100
CBM02YTAN601	600	±25%	100	1.10	50
CBM02YTAN601-1	600	±25%	100	1.00	300
CBM02YTAN102	1000	±25%	100	1.50	50
CBM02YTAN102-1	1000	±25%	100	0.80	250
CBM02YTAN102-2	1000	±25%	100	0.58	300
CBM02YTAN102-3	1000	±25%	100	0.49	350
CBM02YTAN152-2	1500	±25%	100	0.80	250
CBM02YTAN182-2	1800	±25%	100	0.80	250

■ We are capable to design according to customer special requirement

**Multilayer Chip Beads**

**■ Standard Electrical Specifications(for General Signal Line Use)**

CBM03(160808) / A Material

Part No.	Impedance (Ω)	Tolerance	Test Frequency (MHz)	DCR (Ω) max.	Rated Current (mA) max.
CBM03YTAN190	19	±25%	100	0.10	400
CBM03YTAN310	31	±25%	100	0.10	400
CBM03YTAN520	52	±25%	100	0.15	400
CBM03YTAN600	60	±25%	100	0.15	400
CBM03YTAN750	75	±25%	100	0.15	400
CBM03YTAN800	80	±25%	100	0.15	400
CBM03YTAN101	100	±25%	100	0.15	400
CBM03YTAN121	120	±25%	100	0.15	400
CBM03YTAN151	150	±25%	100	0.15	400
CBM03YTAN181	180	±25%	100	0.20	400
CBM03YTAN201	200	±25%	100	0.20	400
CBM03YTAN221	220	±25%	100	0.20	400
CBM03YTAN301	300	±25%	100	0.30	400
CBM03YTAN401	400	±25%	100	0.30	400
CBM03YTAN401-1	400	±25%	100	0.20	500
CBM03YTAN421	420	±25%	100	0.30	400
CBM03YTAN451	450	±25%	100	0.30	400
CBM03YTAN601	600	±25%	100	0.35	400
CBM03YTAN751	750	±25%	100	0.35	400
CBM03YTAN102	1000	±25%	100	0.55	300
CBM03YTAN102-1	1000	±25%	100	0.25	800
CBM03YTAN152	1500	±25%	100	0.60	200

CBM05(201209) / A Material

Part No.	Impedance (Ω)	Tolerance	Test Frequency (MHz)	DCR (Ω) max.	Rated Current (mA) max.
CBM05YTAN170	17	±25%	100	0.10	300
CBM05YTAN260	26	±25%	100	0.10	300
CBM05YTAN300	30	±25%	100	0.10	300
CBM05YTAN310	31	±25%	100	0.10	300
CBM05YTAN520	52	±25%	100	0.15	300
CBM05YTAN600	60	±25%	100	0.15	300
CBM05YTAN800	80	±25%	100	0.15	300
CBM05YTAN101	100	±25%	100	0.20	300
CBM05YTAN121	120	±25%	100	0.20	300
CBM05YTAN151	150	±25%	100	0.20	300
CBM05YTAN221	220	±25%	100	0.25	300
CBM05YTAN301	300	±25%	100	0.25	300
CBM05YTAN401	400	±25%	100	0.30	300
CBM05YTAN531	530	±25%	100	0.35	300
CBM05YTAN601	600	±25%	100	0.35	300
CBM05YTAN102	1000	±25%	100	0.45	300
CBM05YTAN152	1500	±25%	100	0.70	300

■ We are capable to design according to customer special requirement

**Multilayer Chip Beads**

**■ Standard Electrical Specifications(for General Signal Line Use)**

CBM04(321611) / A Material

Part No.	Impedance (Ω)	Tolerance	Test Frequency (MHz)	DCR (Ω) max.	Rated current (mA) max.
CBM04YTAN190	19	±25%	100	0.10	800
CBM04YTAN260	26	±25%	100	0.10	800
CBM04YTAN310	31	±25%	100	0.10	800
CBM04YTAN520	52	±25%	100	0.15	800
CBM04YTAN600	60	±25%	100	0.15	500
CBM04YTAN700	70	±25%	100	0.15	500
CBM04YTAN101	100	±25%	100	0.20	450
CBM04YTAN121	120	±25%	100	0.20	450
CBM04YTAN151	150	±25%	100	0.20	450
CBM04YTAN221	220	±25%	100	0.20	350
CBM04YTAN301	300	±25%	100	0.20	350
CBM04YTAN401	400	±25%	100	0.25	350
CBM04YTAN601	600	±25%	100	0.25	350
CBM04YTAN601-1	600	±25%	100	0.25	500
CBM04YTAN751	750	±25%	100	0.30	350
CBM04YTAN801	800	±25%	100	0.30	350
CBM04YTAN102	1000	±25%	100	0.35	350
CBM04YTAN152	1500	±25%	100	0.40	350
CBM04YTAN152-1	1500	±25%	100	0.20	800

CBM10(322513) / A Material

Part No.	Impedance (Ω)	Tolerance	Test Frequency (MHz)	DCR (Ω) max.	Rated Current (mA) max.
CBM10YTAN310	31	±25%	100	0.10	500
CBM10YTAN520	52	±25%	100	0.30	400
CBM10YTAN600	60	±25%	100	0.30	400

CBM08(451616) / A Material

Part No.	Impedance (Ω)	Tolerance	Test Frequency (MHz)	DCR (Ω) max.	Rated Current (mA) max.
CBM08YTAN600	60	±25%	100	0.20	500
CBM08YTAN800	80	±25%	100	0.30	400
CBM08YTAN101	100	±25%	100	0.30	400
CBM08YTAN151	150	±25%	100	0.50	200
CBM08YTAN601	600	±25%	100	0.80	200

CBM12(453215) / A Material

Part No.	Impedance (Ω)	Tolerance	Test Frequency (MHz)	DCR (Ω) max.	Rated Current (mA) max.
CBM12YTAN310	31	±25%	100	0.10	500
CBM12YTAN600	60	±25%	100	0.20	500
CBM12YTAN121	120	±25%	100	0.20	500
CBM12YTAN151	150	±25%	100	0.20	500

■ We are capable to design according to customer special requirement

**Multilayer Chip Beads****■ Standard Electrical Specifications(for High Speed Signal Line Use)**

CBM02(100505) / B Material

Part No.	Impedance (Ω)	Tolerance	Test Freq. (MHz)	DCR (Ω) max.	Rated Current (mA) max.
CBM02YTBN300	30	±25%	100	0.20	300
CBM02YTBN600	60	±25%	100	0.40	200
CBM02YTBN101	100	±25%	100	0.50	200
CBM02YTBN121	120	±25%	100	0.50	200
CBM02YTBN221	220	±25%	100	0.80	100
CBM02YTBN301	300	±25%	100	0.85	100
CBM02YTBN471	470	±25%	100	1.00	100
CBM02YTBN601	600	±25%	100	1.50	50
CBM02YTBN102	1000	±25%	100	1.00	200

CBM03(160808) / B Material

Part No.	Impedance (Ω)	Tolerance	Test Frequency (MHz)	DCR (Ω) max.	Rated Current (mA) max.
CBM03YTBN050	5	±25%	100	0.08	700
CBM03YTBN300	30	±25%	100	0.20	500
CBM03YTBN470	47	±25%	100	0.20	500
CBM03YTBN600	60	±25%	100	0.25	450
CBM03YTBN101	100	±25%	100	0.30	450
CBM03YTBN121	120	±25%	100	0.30	450
CBM03YTBN151	150	±25%	100	0.35	450
CBM03YTBN221	220	±25%	100	0.35	450
CBM03YTBN301	300	±25%	100	0.35	450
CBM03YTBN471	470	±25%	100	0.35	450
CBM03YTBN601	600	±25%	100	0.40	450
CBM03YTBN102	1000	±25%	100	0.60	300

CBM05(201209) / B Material

Part No.	Impedance (Ω)	Tolerance	Test Frequency (MHz)	DCR (Ω) max.	Rated Current (mA) max.
CBM05YTBN050	5	±25%	100	0.07	500
CBM05YTBN300	30	±25%	100	0.15	300
CBM05YTBN600	60	±25%	100	0.15	300
CBM05YTBN750	75	±25%	100	0.20	300
CBM05YTBN101	100	±25%	100	0.20	300
CBM05YTBN121	120	±25%	100	0.20	300
CBM05YTBN221	220	±25%	100	0.25	200
CBM05YTBN301	300	±25%	100	0.25	200
CBM05YTBN401	400	±25%	100	0.20	300
CBM05YTBN601	600	±25%	100	0.25	200
CBM05YTBN751	750	±25%	100	0.30	200
CBM05YTBN102	1000	±25%	100	0.30	200
CBM05YTBN152	1500	±25%	100	0.35	200
CBM05YTBN182	1800	±25%	100	0.40	200
CBM05YTBN202	2000	±25%	100	0.40	200
CBM05YTBN222	2200	±25%	100	0.50	200
CBM05YTBN252	2500	±25%	100	0.60	200
CBM05YTBN272	2700	±25%	100	0.60	200

■ We are capable to design according to customer special requirement

**Multilayer Chip Beads**

**■ Standard Electrical Specifications(for High Speed Signal Line Use)**

CBM04(321611) / B Material

Part No.	Impedance (Ω)	Tolerance	Test Frequency (MHz)	DCR (Ω) max.	Rated current (mA) max.
CBM04YTBN190	19	±25%	100	0.10	500
CBM04YTBN310	31	±25%	100	0.15	500
CBM04YTBN600	60	±25%	100	0.20	500
CBM04YTBN101	100	±25%	100	0.25	300
CBM04YTBN121	120	±25%	100	0.25	300
CBM04YTBN201	200	±25%	100	0.25	300
CBM04YTBN301	300	±25%	100	0.30	300
CBM04YTBN601	600	±25%	100	0.35	300
CBM04YTBN751	750	±25%	100	0.35	300
CBM04YTBN102	1000	±25%	100	0.40	200
CBM04YTBN152	1500	±25%	100	0.45	200
CBM04YTBN202	2000	±25%	30	0.60	200

CBM10(322513) / B Material

Part No.	Impedance (Ω)	Tolerance	Test Frequency (MHz)	DCR (Ω) max.	Rated Current (mA) max.
CBM10YTBN310	31	±25%	100	0.10	500

CBM12(453215) / B Material

Part No.	Impedance (Ω)	Tolerance	Test Frequency (MHz)	DCR (Ω) max.	Rated Current (mA) max.
CBM12YTBN700	70	±25%	100	0.20	500

■ We are capable to design according to customer special requirement

**Multilayer Chip Beads**

**■ Standard Electrical Specifications(for General Signal Line Frequency Higher Than A Use)**

CBM02(100505) / K Material

Part No.	Impedance (Ω)	Tolerance	Test Freq. (MHz)	DCR (Ω) max.	Rated Current (ma) max.
CBM02YTKN300	30	±25%	100	0.15	300
CBM02YTKN600	60	±25%	100	0.30	200
CBM02YTKN101	100	±25%	100	0.50	200
CBM02YTKN121	120	±25%	100	0.50	200
CBM02YTKN221	220	±25%	100	0.80	100
CBM02YTKN221-1	220	±25%	100	0.35	800
CBM02YTKN301	300	±25%	100	0.85	100
CBM02YTKN471	470	±25%	100	1.00	100
CBM02YTKN601	600	±25%	100	1.50	50

CBM03(160808) / K Material

Part No.	Impedance (Ω)	Tolerance	Test Frequency (MHz)	DCR (Ω) max.	Rated Current (mA) max.
CBM03YTKN471	470	±25%	100	0.55	200
CBM03YTKN601	600	±25%	100	0.65	200
CBM03YTKN751	750	±25%	100	0.70	200
CBM03YTKN102	1000	±25%	100	0.85	100
CBM03YTKN122	1200	±25%	100	0.85	100
CBM03YTKN152	1500	±25%	100	0.90	100
CBM03YTKN152-1	1500	±25%	100	0.40	500
CBM03YTKN202	2000	±25%	100	1.00	100
CBM03YTKN222-1	2200	±25%	100	0.80	50
CBM03YTKN252	2500	±25%	100	1.00	50
CBM03YTKN252-1	2500	±25%	100	0.70	150
CBM03YTKN252-2	2500	±25%	100	0.80	200

CBM05(201209) / K Material

Part No.	Impedance (Ω)	Tolerance	Test Frequency (MHz)	DCR (Ω) max.	Rated Current (mA) max.
CBM05YTKN800	80	±25%	100	0.30	300
CBM05YTKN601	600	±25%	100	0.35	200
CBM05YTKN751	750	±25%	100	0.35	200
CBM05YTKN102	1000	±25%	100	0.40	200
CBM05YTKN122	1200	±25%	100	0.40	200
CBM05YTKN152	1500	±25%	100	0.45	200
CBM05YTKN202	2000	±25%	100	0.60	200
CBM05YTKN222	2200	±25%	100	0.60	200
CBM05YTKN252	2500	±25%	100	0.70	200
CBM05YTKN502	5000	±25%	50	0.60	300

CBM04(321611) / K Material

Part No.	Impedance (Ω)	Tolerance	Test Frequency (MHz)	DCR (Ω) max.	Rated current (mA) max.
CBM04YTKN601	600	±25%	100	0.50	200
CBM04YTKN102	1000	±25%	100	0.70	200
CBM04YTKN122	1200	±25%	100	0.70	200
CBM04YTKN202	2000	±25%	100	0.40	500

■ We are capable to design according to customer special requirement



**Multilayer Chip Beads**

**■ Standard Electrical Specifications(for Ultra High Speed Signal Line Use)**

CBM02(100505) / H Material

Part No.	Impedance (Ω)	Tolerance	Test Freq. (MHz)	DCR (Ω) max.	Rated Current (mA) max.
CBM02YTHN100	10	±25%	100	0.10	500
CBM02YTHN300	30	±25%	100	0.20	300
CBM02YTHN330	33	±25%	100	0.40	300
CBM02YTHN600	60	±25%	100	0.40	300
CBM02YTHN101	100	±25%	100	0.55	300
CBM02YTHN121	120	±25%	100	0.55	300
CBM02YTHN221	220	±25%	100	0.80	200
CBM02YTHN301	300	±25%	100	1.00	100
CBM02YTHN471	470	±25%	100	1.50	50
CBM02YTHN601	600	±25%	100	2.50	50

CBM03(160808) / H Material

Part No.	Impedance (Ω)	Tolerance	Test Frequency (MHz)	DCR (Ω) max.	Rated Current (mA) max.
CBM03YTHN070	7	±25%	100	0.10	900
CBM03YTHN100	10	±25%	100	0.10	900
CBM03YTHN200	20	±25%	100	0.20	600
CBM03YTHN470	47	±25%	100	0.30	500
CBM03YTHN680	68	±25%	100	0.10	700
CBM03YTHN121	120	±25%	100	0.30	300
CBM03YTHN301	300	±25%	100	0.35	300
CBM03YTHN601	600	±25%	100	0.65	300
CBM03YTHN102	1000	±25%	100	1.10	50

CBM05(201209) / H Material

Part No.	Impedance (Ω)	Tolerance	Test Frequency (MHz)	DCR (Ω) max.	Rated Current (mA) max.
CBM05YTHN050	5	±25%	100	0.07	500
CBM05YTHN070	7	±25%	100	0.07	500
CBM05YTHN100	10	±25%	100	0.07	500
CBM05YTHN121	120	±25%	100	0.35	300
CBM05YTHN601	600	±25%	100	0.65	200

CBM04(321611) / H Material

Part No.	Impedance (Ω)	Tolerance	Test Frequency (MHz)	DCR (Ω) max.	Rated current (mA) max.
CBM04YTHN050	5	±25%	100	0.07	500
CBM04YTHN070	7	±25%	100	0.07	500
CBM04YTHN301	300	±25%	100	0.30	300
CBM04YTHN601	600	±25%	100	0.45	300

■ We are capable to design according to customer special requirement

**■ Standard Electrical Specifications(For Medium Current Line Use)**

CBM02(100505) / A Material

Part No.	Impedance (Ω)	Tolerance	Test Frequency (MHz)	DCR (Ω) max.	Rated current (mA) max.
CBM02YTAG100	10	±25%	100	0.03	2000
CBM02YTAG300	30	±25%	100	0.03	3000
CBM02YTAG300-2	30	±25%	100	0.035	2200
CBM02YTAG101	100	±25%	100	0.09	1200
CBM02YTAG121	120	±25%	100	0.09	1200
CBM02YTAG121-1	120	±25%	100	0.09	1300
CBM02YTAG221	220	±25%	100	0.20	1000

**Multilayer Chip Beads**

**■ Standard Electrical Specifications(For Medium Current Line Use)**

CBM03(160808) / A Material

Part No.	Impedance (Ω)	Tolerance	Test Frequency (MHz)	DCR (Ω) max.	Rated current (mA) max.
CBM03YTAG300	30	±25%	100	0.04	3000
CBM03YTAG300-1	30	±25%	100	0.02	4000
CBM03YTAG300-2	30	±25%	100	0.03	3000
CBM03YTAG330	33	±25%	100	0.025	3000
CBM03YTAG600	60	±25%	100	0.04	3000
CBM03YTAG101	100	±25%	100	0.05	3000
CBM03YTAG121	120	±25%	100	0.05	2000
CBM03YTAG181	180	±25%	100	0.08	2000
CBM03YTAG221	220	±25%	100	0.08	2000
CBM03YTAG301	300	±25%	100	0.15	2000
CBM03YTAG301-1	300	±25%	100	0.08	1000
CBM03YTAG331-1	330	±25%	100	0.07	2000
CBM03YTAG471	470	±25%	100	0.15	1500
CBM03YTAG471-1	470	±25%	100	0.25	1000
CBM03YTAG601	600	±25%	100	0.30	1000
CBM03YTAG601-1	600	±25%	100	0.10	2000
CBM03YTAG751	750	±25%	100	0.30	1000
CBM03YTAG102	1000	±25%	100	0.25	1000

CBM05(201209) / A Material

Part No.	Impedance (Ω)	Tolerance	Test Frequency (MHz)	DCR (Ω) max.	Rated current (mA) max.
CBM05YTAG110	11	±25%	100	0.03	3000
CBM05YTAG170	17	±25%	100	0.03	3000
CBM05YTAG300	30	±25%	100	0.05	3000
CBM05YTAG310	31	±25%	100	0.03	3000
CBM05YTAG390	39	±25%	100	0.03	3000
CBM05YTAG470	47	±25%	100	0.03	3000
CBM05YTAG500	50	±25%	100	0.03	3000
CBM05YTAG520	52	±25%	100	0.03	3000
CBM05YTAG600	60	±25%	100	0.04	3000
CBM05YTAG800	80	±25%	100	0.04	3000
CBM05YTAG101	100	±25%	100	0.04	3000
CBM05YTAG121	120	±25%	100	0.05	3000
CBM05YTAG181	180	±25%	100	0.05	3000
CBM05YTAG221	220	±25%	100	0.05	3000
CBM05YTAG301	300	±25%	100	0.05	3000
CBM05YTAG331	330	±25%	100	0.05	3000
CBM05YTAG471	470	±25%	100	0.10	2000
CBM05YTAG601	600	±25%	100	0.10	2000
CBM05YTAG601-1	600	±25%	100	0.30	1000
CBM05YTAG102-1	1000	±25%	100	0.12	1500
CBM05YTAG152	1500	±25%	100	0.30	1000

CBM05(201209) / H Material

Part No.	Impedance (Ω)	Tolerance	Test Frequency (MHz)	DCR (Ω) max.	Rated current (mA) max.
CBM05YTHG100	10	±25%	100	0.03	3000

**Multilayer Chip Beads**

**■ Standard Electrical Specifications(For Medium Current Line Use)**

CBM04(321611) / A Material

Part No.	Impedance (Ω)	Tolerance	Test Frequency (MHz)	DCR (Ω) max.	Rated current (mA) max.
CBM04YTAG190	19	±25%	100	0.03	3000
CBM04YTAG310	31	±25%	100	0.03	3000
CBM04YTAG520	52	±25%	100	0.03	3000
CBM04YTAG700	70	±25%	100	0.04	3000
CBM04YTAG800	80	±25%	100	0.04	3000
CBM04YTAG101	100	±25%	100	0.04	3000
CBM04YTAG121	120	±25%	100	0.05	3000
CBM04YTAG151	150	±25%	100	0.05	3000
CBM04TTAG181	180	±25%	100	0.05	3000
CBM04YTAG221	220	±25%	100	0.05	3000
CBM04YTAG301	300	±25%	100	0.06	3000
CBM04YTAG501	500	±25%	100	0.07	2500
CBM04YTAG601	600	±25%	100	0.08	2000
CBM04YTAG102	1000	±25%	100	0.30	1000

CBM10(322513) / A Material

Part No.	Impedance (Ω)	Tolerance	Test Frequency (MHz)	DCR (Ω) max.	Rated current (mA) max.
CBM10YTAG520	52	±25%	100	0.03	3000
CBM10YTAG600	60	±25%	100	0.03	3000

CBM08(451616) / A Material

Part No.	Impedance (Ω)	Tolerance	Test Frequency (MHz)	DCR (Ω) max.	Rated current (mA) max.
CBM08YTAG600	60	±25%	100	0.04	3000
CBM08YTAG800	80	±25%	100	0.04	3000
CBM08YTAG101	100	±25%	100	0.04	3000
CBM08YTAG181	180	±25%	100	0.04	3000
CBM08YTAG471	470	±25%	100	0.09	2000
CBM08YTAG851	850	±25%	100	0.10	1500
CBM08YTAG102	1000	±25%	100	0.09	1500

CBM12(453215) / A Material

Part No.	Impedance (Ω)	Tolerance	Test Frequency (MHz)	DCR (Ω) max.	Rated current (mA) max.
CBM12YTAG121	120	±25%	100	0.04	3000
CBM12YTAG151	150	±25%	100	0.04	3000

CBM03(160808) / H Material

Part No.	Impedance (Ω)	Tolerance	Test Frequency (MHz)	DCR (Ω) max.	Rated current (mA) max.
CBM03YTHG100	10	±25%	100	0.03	3000

CBM12(453215) / K Material

Part No.	Impedance (Ω)	Tolerance	Test Frequency (MHz)	DCR (Ω) max.	Rated current (mA) max.
CBM12YTKG601	600	±25%	100	0.04	3000
CBM12YTKG781	780	±25%	100	0.04	3000

■ We are capable to design according to customer special requirement

**Multilayer Chip Beads**

**■ Standard Electrical Specifications(For High Current Line Use)**

CBM05(201209) / A Material

Part No.	Impedance (Ω)	Tolerance	Test Frequency (MHz)	DCR (Ω) max.	Rated current (mA) max.
CBM05YTAH170	17	±25%	100	0.008	6000
CBM05YTAH220	22	±25%	100	0.008	6000
CBM05YTAH300	30	±25%	100	0.008	6000
CBM05YTAH300-1	30	±25%	100	0.015	4000
CBM05YTAH390	39	±25%	100	0.008	6000
CBM05YTAH500	50	±25%	100	0.010	6000
CBM05YTAH600	60	±25%	100	0.020	6000
CBM05YTAH800	80	±25%	100	0.020	6000
CBM05YTAH800-2	80	±25%	100	0.010	5000
CBM05YTAH101	100	±25%	100	0.020	5000
CBM05YTAH121	120	±25%	100	0.020	4000
CBM05YTAH121-1	120	±25%	100	0.015	5000

CBM04(321611) / A Material

Part No.	Impedance (Ω)	Tolerance	Test Frequency (MHz)	DCR (Ω) max.	Rated current (mA) max.
CBM04YTAH260	26	±25%	100	0.006	6000
CBM04YTAH310	31	±25%	100	0.006	6000
CBM04YTAH480	48	±25%	100	0.008	6000
CBM04YTAH500	50	±25%	100	0.008	6000
CBM04YTAH520	52	±25%	100	0.008	6000
CBM04YTAH600	60	±25%	100	0.020	4000
CBM04YTAH800	80	±25%	100	0.020	4000
CBM04YTAH121	120	±25%	100	0.020	4000

CBM10(322513) / A Material

Part No.	Impedance (Ω)	Tolerance	Test Frequency (MHz)	DCR (Ω) max.	Rated current (mA) max.
CBM10YTAH520	52	±25%	100	0.008	6000
CBM10YTAH600	60	±25%	100	0.008	6000

CBM08(451616) / A Material

Part No.	Impedance (Ω)	Tolerance	Test Frequency (MHz)	DCR (Ω) max.	Rated current (mA) max.
CBM08YTAH600	60	±25%	100	0.008	6000
CBM08YTAH750	75	±25%	100	0.008	6000
CBM08YTAH800	80	±25%	100	0.008	6000

CBM12(453215) / A Material

Part No.	Impedance (Ω)	Tolerance	Test Frequency (MHz)	DCR (Ω) max.	Rated current (mA) max.
CBM12YTAH600	60	±25%	100	0.008	6000
CBM12YTAH800	80	±25%	100	0.008	6000
CBM12YTAH101	100	±25%	100	0.010	8000
CBM12YTAH121	120	±25%	100	0.020	6000
CBM12YTAH151	150	±25%	100	0.020	6000
CBM12YTAH191	190	±25%	100	0.020	4000

CBM12(453215) / K Material

Part No.	Impedance (Ω)	Tolerance	Test Frequency (MHz)	DCR (Ω) max.	Rated current (mA) max.
CBM12YTKH881	880	±25%	100	0.030	4000

■ We are capable to design according to customer special requirement

**Multilayer Chip Beads**

**Standard Electrical Specifications(For High Current Line Use)**

CBM20(565015) / I Material

Part No.	Impedance (Ω)	Tolerance	Test Frequency (MHz)	DCR (Ω) max.	Rated current (mA) max.
CBM20YTIH171	170	±25%	100	0.030	4000

CBM20(565018) / I Material

Part No.	Impedance (Ω)	Tolerance	Test Frequency (MHz)	DCR (Ω) max.	Rated current (mA) max.
CBM20YTIH151	150	±25%	100	0.015	5000

CBM20(565030) / I Material

Part No.	Impedance (Ω)	Tolerance	Test Frequency (MHz)	DCR (Ω) max.	Rated current (mA) max.
CBM20YTIH601	600	±25%	100	0.025	4000

**Standard Electrical Specifications(For High Frequency Line Use)**

CBM02(100505) / A Material

Part No.	Impedance(Ω) @100MHz	Tolerance	Impedance(Ω) @1GHz	Tolerance	DCR (Ω) max.	Rated current (mA) max.
CBM02YTAF301	300	±25%	560	±40%	0.800	200
CBM02YTAF471	470	±25%	1000	±40%	1.000	100
CBM02YTAF601	600	±25%	1100	±40%	1.200	100
CBM02YTAF102	1000	±25%	1700	±40%	1.600	100
CBM02YTAF182	1800	±25%	1500	±40%	2.200	200

CBM03(160808) / A Material

Part No.	Impedance(Ω) @100MHz	Tolerance	Impedance(Ω) @1GHz	Tolerance	DCR (Ω) max.	Rated current (mA) max.
CBM03YTAF601	600	±25%	600	±40%	0.900	100
CBM03YTAF102	1000	±25%	1200	±40%	1.500	50

CBM03(160808) / H Material

Part No.	Impedance(Ω) @100MHz	Tolerance	Impedance(Ω) @1GHz	Tolerance	DCR (Ω) max.	Rated current (mA) max.
CBM03YTHF121	120	±25%	500	±40%	0.500	200
CBM03YTHF221	220	±25%	1100	±40%	0.800	100
CBM03YTHF331	330	±25%	1300	±40%	1.200	50

**Standard Electrical Specifications(For High Current /High Frequency Line Use)**

CBM20(565020) / I Material

Part No.	Impedance (Ω)	Tolerance	Test Frequency (MHz)	DCR (Ω) max.	Rated current (mA) max.
CBM20YTIC551	550	±25%	100	0.035	4000

**Soldering Condition**

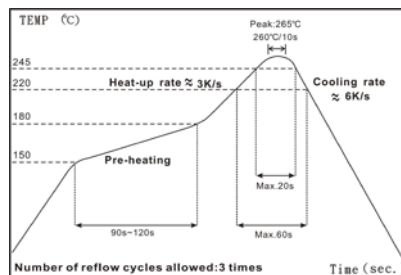

IR Reflow Soldering

- (1) Time of IR reflow soldering at maximum temperature point 260°C : 10s
- (2) Time of soldering iron at maximum temperature point 280°C : 3s



**Multilayer Chip Beads**

**■ Environmental Characteristics**

Electrical Performance Test

Item	Specification	Test Methods
Impedance	Refer to standard electrical spec.	HP4286A
DCR		HP 4338 digital mili-ohm meter

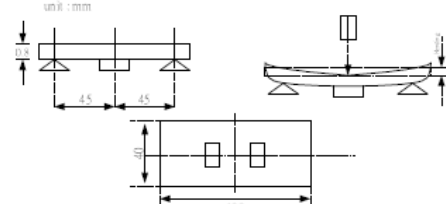
Mechanical Performance Test

Item	Specification	Test Methods
Substrate Bending Test	Without deformation cases Impedance: within±30% of initial value DC Resistance shall be satisfied	Test device shall be soldered on the substrate Substrate Dimension:100x40x0.8mm Deflection: 3.0mm Keeping Time: 10sec and then return 
Vibration	Appearance: No damage Impedance: within±30% of initial value DC Resistance shall be satisfied	Test device shall be soldered on the substrate Oscillation Frequency : 10 to 55 to 10Hz for 1min Amplitude : 1.5mm(peak-peak) Time : 2hrs for each axis (X,Y&Z), total 6hrs
Resistance to Soldering Heat	No visible damage Electrical characteristics and mechanical characteristics shall be satisfied	Solder temp: 265±5°C Immersion time: 6±1sec Preheating: 100°C to 150°C, 1 minute Measured after exposure in the room condition for 24hrs Solder: Sn-3Ag-0.5Cu
Solderability	95% min. coverage of all metallized area	Solder Temperature: 240±5°C Immersion Time: 3±1sec Solder: Sn-3Ag-0.5Cu
Terminal Strength	Without deformation cases Impedance: within±30% of initial value DC Resistance shall be satisfied	Solder chip on PCB and applied 10N (1.02Kgf) for 10 sec 
Temperature Cycle	Appearance: No damage Impedance: within±30% of initial value DC Resistance shall be satisfied	One cycle: One cycle/step1: -55±3°C for 30±3min step2: standard atmospheric conditions 5s or less step3: 125±2°C for 30±3min step4: standard atmospheric conditions 5s or less Total: 100cycles Measured after exposure in the room condition for 24hrs
Humidity Resistance		Temperature: 60±2°C Relative Humidity: 90 ~ 95% Applied Current: Rated Current(maximum value) Time: 1008±12hrs Measured after exposure in the room condition for 24hrs
High Temperature Resistance		Temperature: 125±2°C Applied Current: Rated Current(maximum value) Time: 1008±12hrs Measured after exposure in the room condition for 24hrs
Low Temperature Storage Life Test		Temperature: -55±2°C Time: 1008±12hrs Measured after exposure in the room condition for 24hrs
Thermal Shock		-55°C~125°C kept stabilized for 30 minutes each for 100 cycles Measured after exposure in the room condition for 24hrs

■ Operating Temperature: -55°C ~ 125°C

■ Storage Temperature: 15~28°C ; Humidity < 80%RH

**Multilayer Chip Beads**

**■Packaging**

Reel Specifications

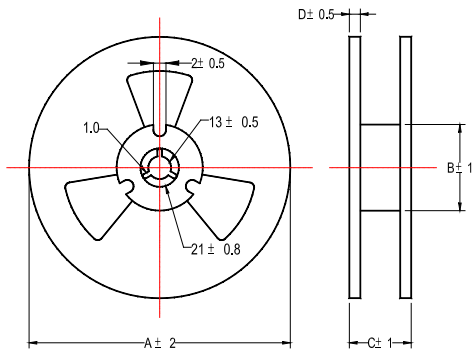

Tape Specifications

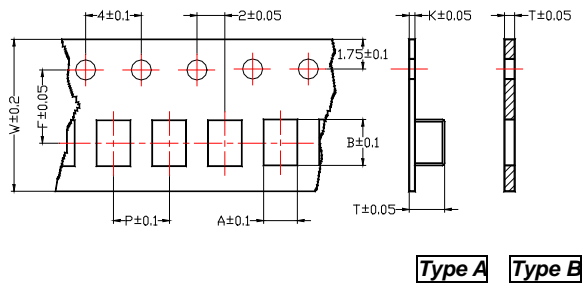

**Type A** **Type B**

Tape Material

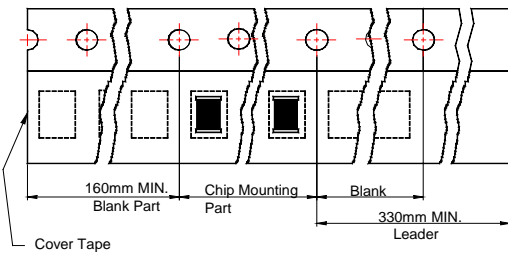

Recommended Pattern

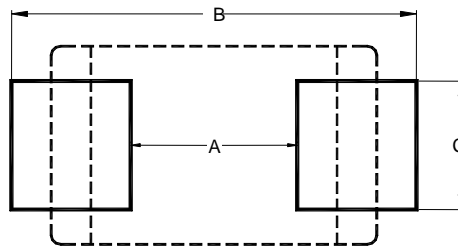

Unit : mm

Type	Tape Dimensions								Reel Dimensions				Recommended Pattern			Quantity (EA)
	A	B	T	W	P	F	K	Tape Type	A	B	C	D	A	B	C	
CBM01	0.38	0.68	1.10	8.0	2.0	3.5	-	B	178	60	10	2	0.25	0.69	0.32	15000
CBM02	0.65	1.15	0.80	8.0	2.0	3.5	-	B	178	60	10	2	0.50	2.10	0.55	10000
CBM03	1.10	1.90	1.10	8.0	4.0	3.5	-	B	178	60	10	2	0.60	2.60	0.80	4000
CBM05	1.55	2.30	1.20	8.0	4.0	3.5	-	B	178	60	10	2	0.66	3.23	1.47	4000
CBM04	1.90	3.50	1.40	8.0	4.0	3.5	0.2	A	178	60	10	2	2.20	4.40	2.06	3000
CBM10	2.90	3.60	1.70	8.0	4.0	3.5	0.2	A	178	60	10	2	2.13	4.06	2.74	2000
CBM08	2.90	4.90	1.40	12	4.0	5.5	0.3	A	178	60	14	2	2.70	5.70	2.24	2000
CBM12	3.60	4.90	2.05	12	8.0	5.5	0.3	A	178	60	14	2	2.57	5.90	4.22	1000
CBM20	5.40	5.95	3.42	12	8.0	5.5	0.33	A	330	100	14.5	2	3.05	9.19	6.1	2000