

ALUMINUM ELECTROLYTIC CAPACITORS



WX 5.5mmL Chip Type
series



- Chip type with 5.5mm height.
- Designed for surface mounting on high density PC board.
- Applicable to automatic mounting machine fed with carrier tape.
- Load life of 2000 hours at 85°C.
- Compliant to the RoHS directive (2011/65/EU).

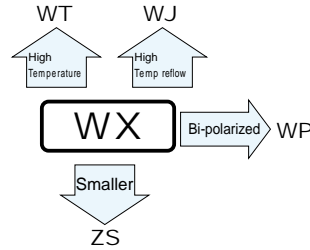

Specifications

Item	Performance Characteristics																										
Category Temperature Range	-40 to +85°C																										
Rated Voltage Range	4 to 50V																										
Rated Capacitance Range	0.1 to 330μF																										
Capacitance Tolerance	±20% at 120Hz, 20°C																										
Leakage Current	After 2 minutes' application of rated voltage, leakage current is not more than 0.01CV or 3 (μA), whichever is greater.																										
Tangent of loss angle (tan δ)	Measurement frequency : 120Hz at 20°C																										
	<table border="1"> <thead> <tr> <th>Rated voltage (V)</th> <th>4</th> <th>6.3</th> <th>10</th> <th>16</th> <th>25</th> <th>35</th> <th>50</th> </tr> </thead> <tbody> <tr> <td>tan δ (MAX.)</td> <td>0.35 (0.40)</td> <td>0.26 (0.30)</td> <td>0.20 (0.24)</td> <td>0.16 (0.19)</td> <td>0.14 (0.16)</td> <td>0.12 (0.14)</td> <td>0.12 (0.14)</td> </tr> </tbody> </table> <p>Values in () applicable to WR, φ3 case size.</p>	Rated voltage (V)	4	6.3	10	16	25	35	50	tan δ (MAX.)	0.35 (0.40)	0.26 (0.30)	0.20 (0.24)	0.16 (0.19)	0.14 (0.16)	0.12 (0.14)	0.12 (0.14)										
Rated voltage (V)	4	6.3	10	16	25	35	50																				
tan δ (MAX.)	0.35 (0.40)	0.26 (0.30)	0.20 (0.24)	0.16 (0.19)	0.14 (0.16)	0.12 (0.14)	0.12 (0.14)																				
Stability at Low Temperature	Measurement frequency : 120Hz																										
	<table border="1"> <thead> <tr> <th colspan="2">Rated voltage (V)</th> <th>4</th> <th>6.3</th> <th>10</th> <th>16</th> <th>25</th> <th>35</th> <th>50</th> </tr> </thead> <tbody> <tr> <td>Impedance ratio</td> <td>Z-25°C / Z+20°C</td> <td>7</td> <td>4</td> <td>3</td> <td>2</td> <td>2</td> <td>2</td> <td>2</td> </tr> <tr> <td>ZT / Z20 (MAX.)</td> <td>Z-40°C / Z+20°C</td> <td>15</td> <td>8</td> <td>8</td> <td>4</td> <td>4</td> <td>3</td> <td>3</td> </tr> </tbody> </table>	Rated voltage (V)		4	6.3	10	16	25	35	50	Impedance ratio	Z-25°C / Z+20°C	7	4	3	2	2	2	2	ZT / Z20 (MAX.)	Z-40°C / Z+20°C	15	8	8	4	4	3
Rated voltage (V)		4	6.3	10	16	25	35	50																			
Impedance ratio	Z-25°C / Z+20°C	7	4	3	2	2	2	2																			
ZT / Z20 (MAX.)	Z-40°C / Z+20°C	15	8	8	4	4	3	3																			
Endurance	<p>The specifications listed at right shall be met when the capacitors are restored to 20°C after the rated voltage is applied for 2000 hours at 85°C.</p> <table border="1"> <tbody> <tr> <td>Capacitance change</td> <td>Within ±20% of the initial capacitance value (Within ±25% for 4V and φ3,WR series units)</td> </tr> <tr> <td>tan δ</td> <td>200% or less than the initial specified value</td> </tr> <tr> <td>Leakage Current</td> <td>Less than or equal to the initial specified value</td> </tr> </tbody> </table>	Capacitance change	Within ±20% of the initial capacitance value (Within ±25% for 4V and φ3,WR series units)	tan δ	200% or less than the initial specified value	Leakage Current	Less than or equal to the initial specified value																				
Capacitance change	Within ±20% of the initial capacitance value (Within ±25% for 4V and φ3,WR series units)																										
tan δ	200% or less than the initial specified value																										
Leakage Current	Less than or equal to the initial specified value																										
Shelf Life	After storing the capacitors under no load at 85°C for 1000 hours and then performing voltage treatment based on JIS C 5101-4 clause 4.1 at 20°C, they shall meet the specified values for the endurance characteristics listed above.																										
Resistance to soldering heat	<p>The capacitors are kept on a hot plate for 30 seconds, which is maintained at 250°C. The capacitors shall meet the characteristic requirements listed at right when they are removed from the plate and restored to 20°C.</p> <table border="1"> <tbody> <tr> <td>Capacitance change</td> <td>Within ±10% of the initial capacitance value</td> </tr> <tr> <td>tan δ</td> <td>Less than or equal to the initial specified value</td> </tr> <tr> <td>Leakage current</td> <td>Less than or equal to the initial specified value</td> </tr> </tbody> </table>	Capacitance change	Within ±10% of the initial capacitance value	tan δ	Less than or equal to the initial specified value	Leakage current	Less than or equal to the initial specified value																				
Capacitance change	Within ±10% of the initial capacitance value																										
tan δ	Less than or equal to the initial specified value																										
Leakage current	Less than or equal to the initial specified value																										
Marking	Black print on the case top.																										

Chip Type

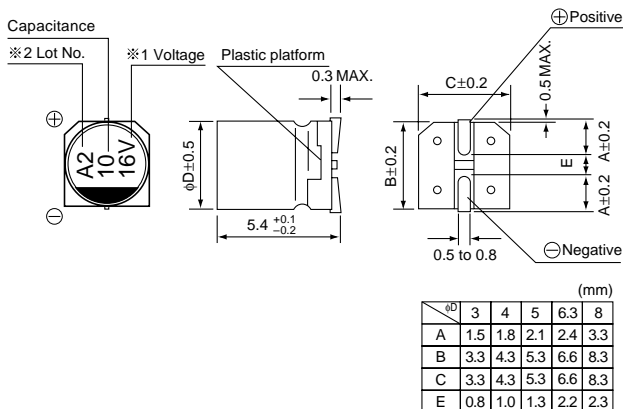

- ※ 1. Voltage mark for 6.3V is 「6V」.
In case of marking for φ3 units, 「V」 for rated voltage is omitted.
- ※ 2. In case of marking for φ3 units, Lot No. is expressed by a digit (month code).

Type numbering system (Example : 16V 10μF)

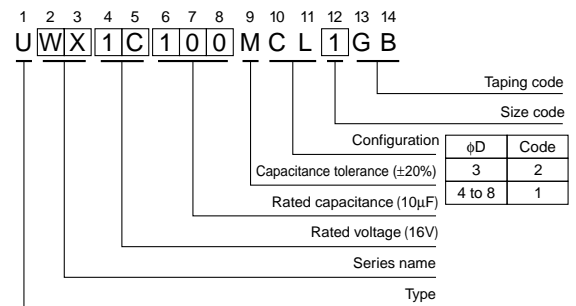

- In the case of size φ3 in (), parentheses, use WX in the 2nd and 3rd digit and put a 2 in the 12th digit of type numbering system.

● Dimension table in next page.

■Dimensions

Cap. (μF)	Code	V		4		6.3		10		16		25		35		50		
		0G	0J	1A	1C	1E	1V	1H										
0.1	0R1																4 (3)	1.0
0.22	R22																4 (3)	2.0
0.33	R33																4 (3)	2.8
0.47	R47																4 (3)	4.0
1	010																4 (3)	8.4 (8.0)
2.2	2R2													3	8.4		4 (3)	13 (10)
3.3	3R3													3	10		4	17
4.7	4R7												4 (3)	16 (12)	4	18	● 5	20 (18)
10	100								4 (3)	23 (18)	● 5	27 (24)	● 5	29 (24)	○ 6.3	33 (30)		
22	220	3	19	4 (3)	28 (21)	● 5	33 (30)	● 5	37 (30)	○ 6.3	42 (38)	○ 6.3	46 (39)	□ 8	52 (43)			
33	330	4	28	● 5	37 (34)	● 5	41 (34)	○ 6.3	49 (44)	○ 6.3	52 (46)	□ 8	62 (53)	8	71			
47	470	4	33	● 5	45 (40)	○ 6.3	52 (47)	○ 6.3	58 (52)	□ 8	70 (60)	8	80					
56	560	5	42	○ 6.3	52 (46)	○ 6.3	57 (50)	○ 6.3	63 (57)	□ 8	76 (65)							
100	101	5	56	○ 6.3	70 (47)	○ 6.3	76 (54)	6.3	86	8	110							
150	151	6.3	79	6.3	71	□ 8	111 (76)											
220	221	6.3	96	□ 8	110 (74)	8	135											
330	331	8	145	8	170											Case size φD (mm)	Rated ripple	

() is also available with φ3mm upon request.

Rated ripple current (mArms) at 85°C 120Hz

• In the case of size φ3 in (), parentheses, use WX at 2nd and 3rd digit and put [2] at the 12th digit of type numbering system. () = φ3 units and WR Series

Size φ4 is available for capacitors marked. " ● "

Size φ5 is available for capacitors marked. " ○ "

Size φ6.3 is available for capacitors marked. " □ "

In such a case, [WR] will be put at 2nd and 3rd digit of type numbering system.

●Frequency coefficient of rated ripple current

Frequency	50 Hz	120 Hz	300 Hz	1 kHz	10 kHz or more
Coefficient	0.70	1.00	1.17	1.36	1.50

- Taping specifications are given in page 23.
- Recommended land size, soldering by reflow are given in page 18, 19.
- Please select UR(p.154), UG(p.162) series if high C/V products are required.
- Please refer to page 3 for the minimum order quantity.

Mouser Electronics

Authorized Distributor

Click to View Pricing, Inventory, Delivery & Lifecycle Information:

Nichicon:

[UWX0G101MCL1GB](#) [UWX0G101MCR1GB](#) [UWX0G220MCL2GB](#) [UWX0G220MCR2GB](#) [UWX0G221MCL1GB](#)
[UWX0G221MCR1GB](#) [UWX0G330MCL1GB](#) [UWX0G330MCR1GB](#) [UWX0G331MCR1GB](#) [UWX0G470MCL1GB](#)
[UWX0G470MCR1GB](#) [UWX0J101MCL1GB](#) [UWX0J101MCR1GB](#) [UWX0J220MCL1GB](#) [UWX0J220MCL2GB](#)
[UWX0J220MCR1GB](#) [UWX0J220MCR2GB](#) [UWX0J221MCL1GB](#) [UWX0J221MCR1GB](#) [UWX0J330MCL1GB](#)
[UWX0J330MCR1GB](#) [UWX0J331MCL1GB](#) [UWX0J331MCR1GB](#) [UWX0J470MCL1GB](#) [UWX0J470MCR1GB](#)
[UWX1A101MCL1GB](#) [UWX1A101MCR1GB](#) [UWX1A220MCL1GB](#) [UWX1A220MCR1GB](#) [UWX1A221MCL1GB](#)
[UWX1A221MCR1GB](#) [UWX1A330MCL1GB](#) [UWX1A330MCR1GB](#) [UWX1A470MCL1GB](#) [UWX1A470MCR1GB](#)
[UWX1C100MCL1GB](#) [UWX1C100MCL2GB](#) [UWX1C100MCR1GB](#) [UWX1C100MCR2GB](#) [UWX1C101MCL1GB](#)
[UWX1C101MCR1GB](#) [UWX1C220MCL1GB](#) [UWX1C220MCR1GB](#) [UWX1C330MCL1GB](#) [UWR1A470MCR1GB](#)
[UWX1C330MCR1GB](#) [UWX1C470MCL1GB](#) [UWX1C470MCR1GB](#) [UWX1C470MCR1MB](#) [UWX1E100MCL1GB](#)
[UWX1E100MCR1GB](#) [UWX1E101MCL1GB](#) [UWX1E101MCR1GB](#) [UWX1E220MCL1GB](#) [UWX1E220MCR1GB](#)
[UWX1E330MCL1GB](#) [UWX1E330MCR1GB](#) [UWX1E330MCR1MB](#) [UWX1E470MCL1GB](#) [UWX1E470MCR1GB](#)
[UWX1E4R7MCL1GB](#) [UWX1E4R7MCL2GB](#) [UWX1E4R7MCR1GB](#) [UWX1E4R7MCR2GB](#) [UWX1H010MCL1GB](#)
[UWX1H010MCL2GB](#) [UWX1H010MCR1GB](#) [UWX1H010MCR2GB](#) [UWX1H0R1MCL1GB](#) [UWX1H0R1MCL2GB](#)
[UWX1H0R1MCR1GB](#) [UWX1H0R1MCR2GB](#) [UWX1H100MCL1GB](#) [UWX1H100MCR1GB](#) [UWX1H220MCL1GB](#)
[UWX1H220MCR1GB](#) [UWX1H2R2MCL1GB](#) [UWX1H2R2MCL2GB](#) [UWX1H2R2MCR1GB](#) [UWX1H2R2MCR2GB](#)
[UWX1H330MCL1GB](#) [UWX1H330MCR1GB](#) [UWX1H3R3MCL1GB](#) [UWX1H3R3MCR1GB](#) [UWX1H4R7MCL1GB](#)
[UWX1H4R7MCR1GB](#) [UWX1HR22MCL1GB](#) [UWX1HR22MCL2GB](#) [UWX1HR22MCR1GB](#) [UWX1HR22MCR2GB](#)
[UWX1HR33MCL1GB](#) [UWX1HR33MCL2GB](#) [UWX1HR33MCR1GB](#) [UWX1HR33MCR2GB](#) [UWX1HR47MCL1GB](#)
[UWX1HR47MCL2GB](#) [UWX1HR47MCR1GB](#) [UWX1HR47MCR2GB](#) [UWX1V100MCL1GB](#) [UWX1V100MCR1GB](#)