

SWISSDIS



Swissdis AG
Grasweg 7
CH-4911 Schwarzhäusern

Tel.: +41 62 919 44 00
Fax: +41 62 919 44 01
info@swissdis.ch
www.swissdis.ch



SPECIFICATIONS

Thick Film Chip Resistors

Version May 2023

ROYALOHM

C O N F I D E N T I A L D O C U M E N T

SPECIFICATION FOR APPROVAL

SWISSDIS AG

Description : Thick Film Chip Resistors (Terminal Lead Free)

Royalohm Part no.:

0105WHxxxxxTDE	(RMC (01005) 1/32W +/- 1%, 2%, 5% & Jumper)
0201WMxxxxxTEE	(RMC (0201) 1/20W +/- 1%, 2%, 5% & Jumper)
0402WGxxxxxTCE	(RMC (0402) 1/16W +/- 0.5%, 1%, 2%, 5% & Jumper)
0603WAxxxxxT5E	(RMC (0603) 1/10W +/- 0.5%, 1%, 2%, 5% & Jumper)
0805W8xxxxxT5E	(RMC (0805) 1/8W +/- 0.5%, 1%, 2%, 5% & Jumper)
1206W4xxxxxT5E	(RMC (1206) 1/4W +/- 0.5%, 1%, 2%, 5% & Jumper)
1210W2xxxxxT5E	(RMC (1210) 1/2W +/- 0.5%, 1%, 2%, 5% & Jumper)
181207xxxxxT4E	(RMC (1812) 3/4W +/- 0.5%, 1%, 2%, 5% & Jumper)
201007xxxxxT4E	(RMC (2010) 3/4W +/- 0.5%, 1%, 2%, 5% & Jumper)
25121WxxxxxT4E	(RMC (2512) 1W +/- 0.5%, 1%, 2%, 5% & Jumper)

Approved by

RoHS V3 Compliant (EU) 2015/863
REACH Compliant

Approved	Checked	Prepared
	Issue Date: 2023/05/24	

CHANGE NOTIFICATION HISTORY			
Version	Date of Version	History	Remark
1	2021/01/13	1. CHIP Series (0201, 0402, 0603, 0805, 1206, 1210, 1812, 2010, 2512)	
		2. Resistance tolerance: $\pm 1\%$, $\pm 5\%$ & Jumper	
2	2021/03/29	1. Revised Temperature Cycling: 5 cycles \rightarrow 100 cycles	Page. 7
3	2022/06/15	1. Add New/Old Part No.	Page.12
4	2023/05/09	1. Add E-24	Page. 4
5	2023/05/24	1. Add Low Resistance Size 0402	Page. 3
		2. Add Resistance tolerance: $\pm 0.5\%$, $\pm 2\%$	
		3. Add Size 0105 (01005)	

Thick Film Chip Resistors (Terminal Lead Free)

1. Scope:

This specification for approval relates to Thick Film Chip Resistors (Terminal Lead Free) manufactured by ROYALOHM 's specifications.

2. Type designation:

The type designation shall be in the following form:

Type	Power Rating	Resistance tolerance	Nominal Resistance
Ex. RMC (0603)	1/10W	D, F, G, J	75Ω

3. Ratings:

Type	0105	0201	0402	0603	0805	1206	1210	1812	2010	2512
Power Rating	1/32W	1/20W	1/16W	1/10W	1/8W	1/4W	1/2W	3/4W	3/4W	1W
Max. Working Voltage	15 V	25 V	50 V	75 V	150 V	200 V	200 V	200 V	200 V	200 V
Max. Working Current for Jumper	0.5 A	0.5 A	1 A	1 A	2 A	2 A	2 A	2 A	2 A	2 A
Max. Overload Voltage	30 V	50 V	100 V	150 V	300 V	400 V	500 V	500 V	500 V	500 V
Max. Overload Current for Jumper	1 A	1 A	2 A	2 A	5 A	10 A	10 A	10 A	10 A	10 A
Dielectric Withstanding Voltage	-	-	100 V	300 V	500 V	500 V	500 V	500 V	500 V	500 V
Temperature Range	-55°C ~ +155°C									
Ambient Temperature	70 °C									

3.1 Nominal Resistance

Effective figures of nominal resistance shall be in accordance :

E-24 values – these are preferred and will have standard MOQ

E-96 values – are available on case by case basis and availability and MOQ need to be confirmed with factory first

3.2 Voltage rating:

Resistors shall have a rated direct-current (DC) continuous working voltage or an approximate sine-wave root-mean-square (RMS) alternating-current (AC) continuous working voltage at commercial-line frequency and waveform corresponding to the power rating , as determined from the following formula :

$$RCWV = \sqrt{P \times R}$$

Note : Max. Working Voltage or $\sqrt{P \times R}$ whichever is lesser

Max. Overload Voltage or $2.5 \sqrt{P \times R}$ whichever is lesser

Where : RCWV = Rated DC or RMS AC continuous working voltage at commercial-line frequency and waveform (volt)

P = Power Rating (watt)

R = Nominal Resistance (ohm)

Thick Film Chip Resistors (Terminal Lead Free)

4. Construction :

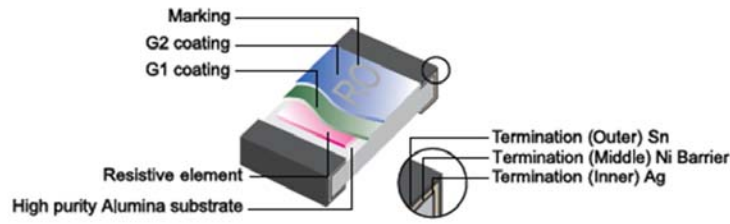

5. Power rating and dimensions

5.1 Power rating:

Resistors shall have a power rating based on continuous load operation at an ambient temperature of 70 °C . For temperature in excess of 70 °C , The load shall be derate as shown in figure 1.

Figure 1

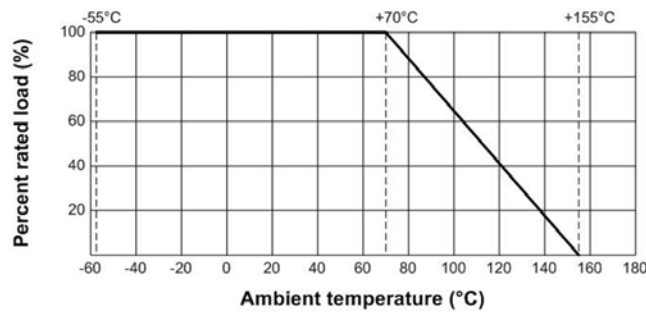

Dimension :

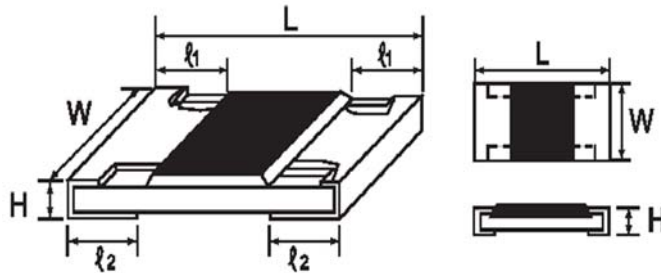

Type	Dimension (mm)				
	L	W	H	ℓ1	ℓ2
RMC (0105)	0.40 ± 0.02	0.20 ± 0.02	0.13 ± 0.02	0.10 ± 0.03	0.10 ± 0.03
RMC (0201)	0.60 ± 0.03	0.30 ± 0.03	0.23 ± 0.03	0.10 ± 0.05	0.15 ± 0.05
RMC (0402)	1.00 ± 0.10	0.50 ± 0.05	0.35 ± 0.05	0.20 ± 0.10	0.25 ± 0.10
RMC (0603)	1.60 ± 0.10	0.80 ± 0.10	0.45 ± 0.10	0.30 ± 0.20	0.30 ± 0.20
RMC (0805)	2.00 ± 0.15	1.25 + 0.15 - 0.10	0.55 ± 0.10	0.40 ± 0.20	0.40 ± 0.20
RMC (1206)	3.10 ± 0.15	1.55 + 0.15 - 0.10	0.55 ± 0.10	0.45 ± 0.20	0.45 ± 0.20
RMC (1210)	3.10 ± 0.10	2.60 ± 0.20	0.55 ± 0.10	0.50 ± 0.25	0.50 ± 0.20
RMC (1812)	4.50 ± 0.20	3.20 ± 0.20	0.55 ± 0.20	0.50 ± 0.20	0.50 ± 0.20
RMC (2010)	5.00 ± 0.10	2.50 ± 0.20	0.55 ± 0.10	0.60 ± 0.25	0.50 ± 0.20
RMC (2512)	6.35 ± 0.10	3.20 ± 0.20	0.55 ± 0.10	0.60 ± 0.25	0.50 ± 0.20

Thick Film Chip Resistors (Terminal Lead Free)

Power Rating :

Type	Power Rating at 70 °C	Tolerance %	Resistance Range	TCR PPM/°C	Standard Series
RMC (0105)	1/32W	Jumper	<50mΩ		
		±1, ±2	10Ω~10MΩ	1Ω≤R<10Ω : -200~+600 10Ω≤R<100Ω : ±300 100Ω≤R≤10MΩ : ±200	E-96, E-24
		±5	1Ω~10MΩ		
RMC (0201)	1/20W	Jumper	<50mΩ		
		±1, ±2, ±5	1Ω~10MΩ	1Ω≤R≤10Ω : -100~+350 > 10Ω : ±200	E-96, E-24
RMC (0402)	1/16W	Jumper	<50mΩ		
		± 0.5	1Ω~10MΩ	0.1Ω≤R<1Ω : ±800 1Ω≤R≤10Ω : ±200 > 10Ω : ±100	E-96, E-24
		±1, ±2, ±5	0.1Ω~10MΩ		
RMC (0603)	1/10W	Jumper	<50mΩ		
		± 0.5	1Ω~10MΩ	0.01Ω≤R≤0.03Ω : ±1500 0.03Ω<R≤0.05Ω : ±1000 0.05Ω<R<1Ω : ±800 1Ω≤R≤10Ω : ±200 > 10 Ω : ±100	E-96, E-24
		±1, ±2, ±5	0.01Ω~10MΩ		
RMC (0805)	1/8W	Jumper	<50mΩ		
		± 0.5	1Ω~10MΩ	0.01Ω≤R≤ 0.015Ω : ±1500 0.015Ω<R≤ 0.03Ω : ±1000 0.03Ω<R<1Ω : ±800 1Ω≤R≤10Ω : ±200 > 10 Ω : ±100	E-96, E-24
		±1, ±2, ±5	0.01Ω~10MΩ		
RMC (1206)	1/4W	Jumper	<50mΩ		
		± 0.5	1Ω~10MΩ	0.01Ω≤R≤ 0.015Ω : ±1500 0.015Ω<R≤ 0.03Ω : ±1000 0.03Ω<R<1Ω : ±800 1Ω≤R≤10Ω : ±200 > 10 Ω : ±100	E-96, E-24
		±1, ±2, ±5	0.01Ω~10MΩ		
RMC (1210)	1/2W	Jumper	<50mΩ		
		± 0.5	1Ω~10MΩ	0.01Ω≤R≤ 0.015Ω : ±1500 0.015Ω<R≤ 0.03Ω : ±1000 0.03Ω<R<1Ω : ±800 1Ω≤R≤10Ω : ±200 > 10 Ω : ±100	E-96, E-24
		±1, ±2, ±5	0.01Ω~10MΩ		
RMC (1812)	3/4W	Jumper	<50mΩ		
		± 0.5	1Ω~10MΩ	0.01Ω≤R≤ 0.015Ω : ±1500 0.015Ω<R≤ 0.03Ω : ±1000 0.03Ω<R<1Ω : ±800 1Ω≤R≤10Ω : ±200 > 10 Ω : ±100	E-96, E-24
		±1, ±2, ±5	0.01Ω~10MΩ		
RMC (2010)	3/4W	Jumper	<50mΩ		
		± 0.5	1Ω~10MΩ	0.01Ω≤R≤ 0.015Ω : ±1500 0.015Ω<R≤ 0.03Ω : ±1000 0.03Ω<R<1Ω : ±800 1Ω≤R≤10Ω : ±200 > 10 Ω : ±100	E-96, E-24
		±1, ±2, ±5	0.01Ω~10MΩ		
RMC (2512)	1W	Jumper	<50mΩ		
		± 0.5	1Ω~10MΩ	0.01Ω≤R≤ 0.015Ω : ±1500 0.015Ω<R≤ 0.03Ω : ±1000 0.03Ω<R<1Ω : ±800 1Ω≤R≤10Ω : ±200 > 10 Ω : ±100	E-96, E-24
		±1, ±2, ±5	0.01Ω~10MΩ		

Thick Film Chip Resistors (Terminal Lead Free)

6. Marking

6.1 Resistors

A. Chip Resistors type 0105, 0201, 0402 No marking

B. ± 0.5%, ± 1% Tolerance 0603 E-96 series use below decoding method:

Multiplier Code :

Code	A	B	C	D	E	F	G	H	X	Y	Z
	0	1	2	3	4	5	6	7	-1	-2	-3
Multiplier	10	10	10	10	10	10	10	10	10	10	10

Coding

Formula

Example :

$$10.2K\Omega = \overset{2}{102} X \overset{2}{10} \Omega = 02C$$

$$33.2\Omega = \overset{2}{332} X \overset{-1}{10} \Omega = 51X$$

XX

Resistance Code

X

Multiplier Code

100	01	162	21	261	41	422	61	681	81
102	02	165	22	267	42	432	62	698	82
105	03	169	23	274	43	442	63	715	83
107	04	174	24	280	44	453	64	732	84
110	05	178	25	287	45	464	65	750	85
113	06	182	26	294	46	475	66	768	86
115	07	187	27	301	47	487	67	787	87
118	08	191	28	309	48	499	68	806	88
121	09	196	29	316	49	511	69	825	89
124	10	200	30	324	50	523	70	845	90
127	11	205	31	332	51	536	71	866	91
130	12	210	32	340	52	549	72	887	92
133	13	215	33	348	53	562	73	909	93
137	14	221	34	357	54	576	74	931	94
140	15	226	35	365	55	590	75	953	95
143	16	232	36	374	56	604	76	976	96
147	17	237	37	383	57	619	77		
150	18	243	38	392	58	634	78		
154	19	249	39	402	59	649	79		
158	20	255	40	412	60	665	80		

*Marking for 0603 E-24, E-96 series, the resistance value that no have multiplier code indicate marking follow this:

The first two digits are significant figures of resistance and the third one denoted number of zeros and under line the marking letters.

Ex.

	<u>122</u>	
--	------------	--

1.2kΩ

Thick Film Chip Resistors (Terminal Lead Free)

A. $\pm 2\%$, $\pm 5\%$ Tolerance 0603, 0805, 1206, 1210, 1812, 2010, 2512: the first two digits are significant figures of resistance and the third denoted number of zeros.

Ex.

	333	
--	-----	--

 33k Ω

B. For ohmic values below 10 Ω

Ex.

	2R2	
--	-----	--

 2.2 Ω

C. For E-96 series [$\pm 0.5\%$, $\pm 1\%$] in 0603 size 3 digit system (due to space restrictions) please refer to page 4 for coding formula

Ex.

	02C	
--	-----	--

 10.2k Ω

D. $\pm 0.5\%$, $\pm 1\%$ Tolerance 0805, 1206, 1210, 1812, 2010, 2512 : 4 Digits, the first three digits are significant figures of resistance and the fourth digit denoted number of zeros. Letter "R" is for decimal point.

Ex.

	2701	
--	------	--

 2.7k Ω

E. Marking for $\pm 0.5\%$, $\pm 1\%$, $\pm 2\%$, $\pm 5\%$ Tolerance 0805, 1206, 1210, 1812, 2010, 2512 (Only for 0.01 Ω ~ 0.099 Ω) : 4 Digits

Ex.

	R091	
--	------	--

 0.091 Ω

Ex.

	R010	
--	------	--

 0.01 Ω

6.2 Labels

Label shall be marked with the following item :

- A. Nominal Resistance and Resistance Tolerance
- B. Power Rating and Size
- C. Quantity
- D. Part No.
- E. P.O.No.
- F. Lot No.

Ex.

ROYALOHM			
CHIP RESISTOR			
RESISTANCE:	75	Ω	$\pm 1\%$
WATTAGE:	1/10W	SIZE:	0603
QUANTITY:	5,000	PCS	Pb-Free
PART NO.:			
P.O.NO.:			
LOT NO. :	825723	0603WAF750JT5E	
			

Remark : For 0603 $\pm 1\%$: Label is 75R, value is 75 Ω , marking is 85X

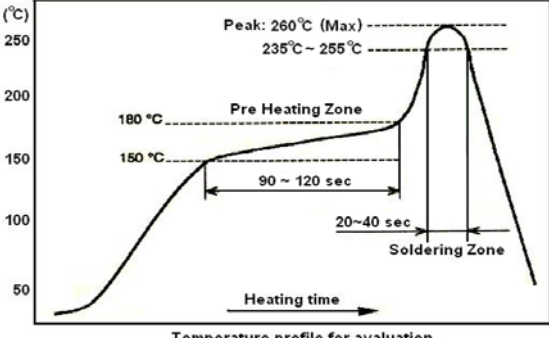
Thick Film Chip Resistors (Terminal Lead Free)		
7. Performance specification :		
Characteristics	Limits	Test Methods (JIS C 5201-1)
*Insulation Resistance	1,000 MΩ or more	Apply 500V DC between protective coating and termination for 1 min, then measure (Sub-clause 4.6)
*Dielectric Withstanding Voltage	No evidence of flashover mechanical damage, arcing or insulation break down	Apply 100V(0402) 300V(0603) & 500V (0805,1206,1210,2010, 2512) AC between protective coating and termination for 1 minute (Sub-clause 4.7)
Temperature Coefficient	Refer to item 5.	Natural resistance change per temp. degree centigrade. $\frac{R_2 - R_1}{R_1(t_2 - t_1)} \times 10^6 \text{ (PPM/°C)}$ R1: Resistance value at room temperature (t1) R2: Resistance value at room temp. plus 100 °C (t2) (Sub-clause 4.8)
Short Time Overload	Resistance change rate is ± 2%, ± 5% : (2.0% + 0.1Ω) Max. ± 0.5%, ± 1% : (1.0% + 0.1Ω) Max.	Permanent resistance change after the application of a potential of 2.5 times RCWV for 5 seconds (Sub-clause 4.13)
*Solderability	95 % coverage Min.	Test temperature of solder : 245 ± 3°C Dipping them solder : 2-3 seconds (Sub-clause 4.17)
Soldering Temperature Reference	Electrical characteristics shall be satisfied. Without distinct deformation in appearance. (95 % coverage Min.)	<p><u>Wave soldering condition:</u> (2 cycles Max.)</p> <p>Pre-heat : 100 ~ 120 °C, 30 ± 5 sec. Suggestion solder temp.: 235 ~ 255 °C, 10 sec. (Max.) Peak temp.: 260 °C</p> <p><u>Reflow soldering condition:</u> (2 cycles Max.)</p> <p>Pre-heat : 150 ~ 180 °C, 90 ~ 120 sec. Suggestion solder temp.: 235 ~ 255 °C, 20 ~ 40 sec. Peak temp.: 260 °C</p>  <p>The graph shows a temperature profile starting at 50°C, rising to a pre-heating zone between 150°C and 180°C for 90 to 120 seconds. It then rises to a soldering zone between 235°C and 255°C for 20 to 40 seconds, reaching a peak of 260°C. The x-axis is labeled 'Heating time' and the y-axis is labeled '(°C)'.</p> <p><u>Hand soldering condition:</u></p> <p>The soldering iron tip temperature should be less than 300°C and maximum contract time should be 5 sec.</p>

Thick Film Chip Resistors (Terminal Lead Free)																	
7. Performance specification :																	
Characteristics	Limits	Test Methods (JIS C 5201-1)															
Soldering Heat	Resistance change rate is: ±(1%+0.05Ω) Max.	Dip the resistor into a solder bath having a temperature of 260°C±3°C and hold it for 10±1 seconds. (Sub-clause 4.18)															
Temperature Cycling	Resistance change rate is ± 2%, ± 5% : (1.0% + 0.05Ω) Max. ± 0.5%, ± 1% : (0.5% + 0.05Ω) Max.	Resistance change after continuous 100 cycles for duty cycle specified below : <table border="1" style="width: 100%; border-collapse: collapse;"> <thead> <tr> <th style="text-align: center;">Step</th> <th style="text-align: center;">Temperature</th> <th style="text-align: center;">Time</th> </tr> </thead> <tbody> <tr> <td style="text-align: center;">1</td> <td style="text-align: center;">-55°C ± 3°C</td> <td style="text-align: center;">30 mins</td> </tr> <tr> <td style="text-align: center;">2</td> <td style="text-align: center;">Room temp.</td> <td style="text-align: center;">10~15 mins</td> </tr> <tr> <td style="text-align: center;">3</td> <td style="text-align: center;">+155°C ± 2°C</td> <td style="text-align: center;">30 mins</td> </tr> <tr> <td style="text-align: center;">4</td> <td style="text-align: center;">Room temp.</td> <td style="text-align: center;">10~15 mins</td> </tr> </tbody> </table> (Sub-clause 4.19)	Step	Temperature	Time	1	-55°C ± 3°C	30 mins	2	Room temp.	10~15 mins	3	+155°C ± 2°C	30 mins	4	Room temp.	10~15 mins
Step	Temperature	Time															
1	-55°C ± 3°C	30 mins															
2	Room temp.	10~15 mins															
3	+155°C ± 2°C	30 mins															
4	Room temp.	10~15 mins															
Load Life in Humidity	Resistance change rate is ± 2%, ± 5% : (3.0% + 0.1Ω) Max. ± 0.5%, ± 1% : (1.0% + 0.1Ω) Max.	Resistance change after 1,000 hours (1.5 hours "on", 0.5 hour "off") at RCWV in a humidity chamber controlled at 40°C ± 2°C and 90 to 95 % relative humidity (Sub-clause 4.24.2.1)															
Load Life	Resistance change rate is ± 2%, ± 5% : (3.0% + 0.1Ω) Max. ± 0.5%, ± 1% : (1.0% + 0.1Ω) Max.	Permanent resistance change after 1,000 hours operating at RCWV, with duty cycle of (1.5 hours"on", 0.5 hour"off") at 70°C ± 2°C ambient (Sub-clause 4.25.1)															
Terminal Bending	Resistance change rate is ± (1.0% + 0.05Ω) Max.	Twist of Test Board : Y/X = 5/90 mm for 10 seconds (Sub-clause 4.33)															
The resistors of 0Ω only can do the characteristic noted of *																	

Thick Film Chip Resistors (Terminal Lead Free)

8. Packing specification :

* Taping Dimension (mm)

A. Paper taping

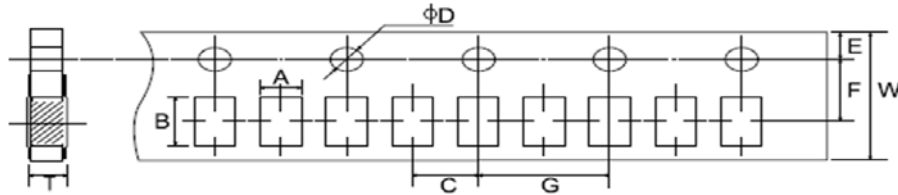

Type	A	B	C ± 0.05	ØD +0.1 - 0	E ± 0.1	F ± 0.05	G ± 0.1	W ± 0.2	T ± 0.1
RMC (0105)	0.24±0.05	0.45±0.05	2.0	1.5	1.75	3.5	4.0	8.0	0.40
RMC (0201)	0.40±0.05	0.70±0.05	2.0	1.5	1.75	3.5	4.0	8.0	0.42
RMC (0402)	0.65±0.1	1.2±0.1	2.0	1.5	1.75	3.5	4.0	8.0	0.42±0.05

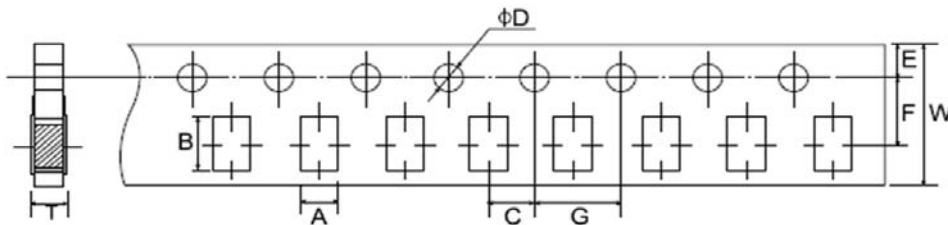

Type	A ± 0.2	B ± 0.2	C ± 0.05	ØD +0.1 - 0	E ± 0.1	F ± 0.05	G ± 0.1	W ± 0.2	T ± 0.1
RMC (0603)	1.10	1.90	2.0	1.5	1.75	3.5	4.0	8.0	0.67
RMC (0805)	1.65	2.40	2.0	1.5	1.75	3.5	4.0	8.0	0.81
RMC (1206)	2.00	3.60	2.0	1.5	1.75	3.5	4.0	8.0	0.81
RMC (1210)	2.80	3.50	2.0	1.5	1.75	3.5	4.0	8.0	0.75

B. Embossed taping

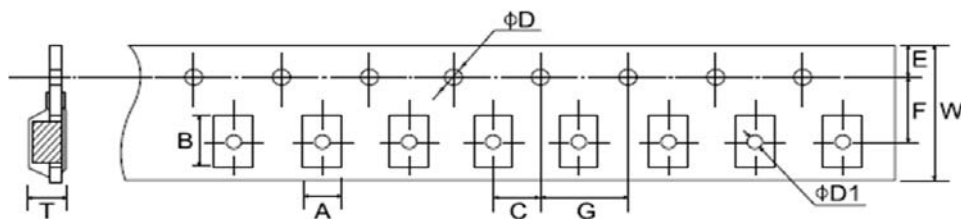

Type	A ± 0.2	B ± 0.2	C ± 0.05	ØD +0.1 - 0	ØD1 +0.1 - 0	E ± 0.1	F ± 0.05	G ± 0.1	W ± 0.2	T ± 0.1
RMC (1812)	3.50	4.80	2.0	1.5	1.5	1.75	5.5	4.0	12.0	1.0
RMC (2010)	2.90	5.60	2.0	1.5	1.5	1.75	5.5	4.0	12.0	1.0
RMC (2512)	3.50	6.70	2.0	1.5	1.5	1.75	5.5	4.0	12.0	1.0

Thick Film Chip Resistors (Terminal Lead Free)

*** Peeling Strength of Top Cover Tape**

Test Condition: 0.1 to 0.7 N at a peel-off speed of 300 mm / min.

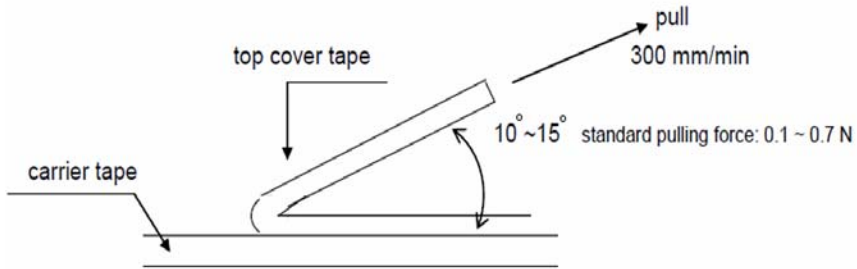

*** Reel Dimension (mm)**

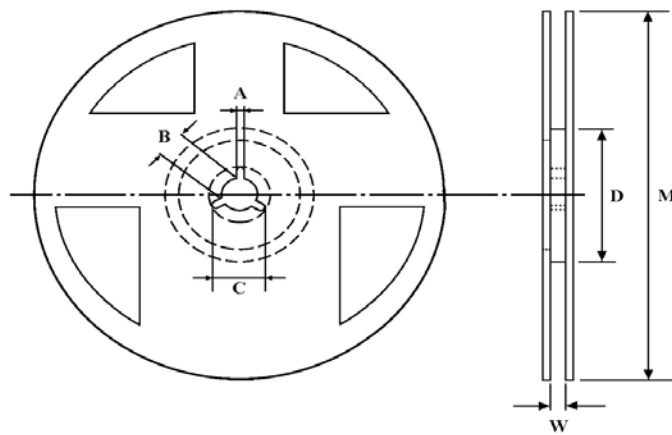

Type	Packaging	Quantity Per Reel	A ± 0.5	B ± 0.5	C ± 0.5	D ± 1	M ± 2	W ± 1
RMC (0105)	Paper	20,000 pcs.	2	13	21	60	178	10
RMC (0201)	Paper	15,000 pcs.	2	13	21	60	178	10
RMC (0402)	Paper	10,000 pcs.	2	13	21	60	178	10
RMC (0603)	Paper	5,000 pcs.	2	13	21	60	178	10
RMC (0805)	Paper	5,000 pcs.	2	13	21	60	178	10
RMC (1206)	Paper	5,000 pcs.	2	13	21	60	178	10
RMC (1210)	Paper	5,000 pcs.	2	13	21	60	178	10
RMC (1812)	Embossed	4,000 pcs.	2	13	21	60	178	13.8
RMC (2010)	Embossed	4,000 pcs.	2	13	21	60	178	13.8
RMC (2512)	Embossed	4,000 pcs.	2	13	21	60	178	13.8

Part Number System

**Explanation of Part Number System
Thick Film Chip Resistors (Terminal Lead Free)**



Product Type:
Fill-in these 4 digits with the Chip resistor types as follows:
0105 (01005)
0201
0402
0603
0805
1206
1210
1812
2010
2512

Wattage:
Normal size:
WH = 1/32W
WM = 1/20W
WG = 1/16W
WA = 1/10W
W8 = 1/8W
W4 = 1/4W
W2 = 1/2W
07 = 3/4W
1W = 1W

Tolerance:
D ~ ± 0.5%
F ~ ± 1%
G ~ ± 2%
J ~ ± 5%

Resistance Value:
2%, 5% series: the 1st digit is "0", the 2nd & 3rd digits are for the significant figures of the resistance and the 4th indicate the number of zeros following;
0.5%, 1% series: the 1st to 3rd digits are for the significant figures of the resistance and the 4th digit indicate the number of zeros following.
Decimal point is expressed :
"J"~ 0.1, "K"~0.01, "L"~0.001
Ex: 2 Ω 26 ~226K, 226 Ω ~2260

Packing Quantity:
4 = 4,000pcs
5 = 5,000pcs
C = 10,000pcs
E = 15,000pcs
D = 20,000pcs

Packing Type:
T = T/R Packing

Special Feature:
E = Lead Free

Sample : RMC 0603 1/10W +/- 1% 75Ω T/R--5,000 → 0603WAF750JT5E
RMC 0603 1/10W +/- 5% 75Ω T/R--5,000 → 0603WAJ0750T5E

Thick Film Chip Resistors (Terminal Lead Free)

Environment Related Substance

This product complies to EU RoHS directive, EU PAHs directive, EU PFOS directive and Halogen free.

Ozone layer depleting substances.

Ozone depleting substances are not used in our manufacturing process of this product.

This product is not manufactured using Chloro fluorocarbons (CFCs), Hydrochlorofluorocarbons (HCFCs), Hydrobromofluorocarbons (HBFCs) or other ozone depleting substances in any phase of the manufacturing process.

Storage Condition (MSL1)

The performance of these products, including the solderability, is guaranteed for a year from the date of arrival at your company, provided that they remain packed as they were when delivered and stored at a temperature of $25^{\circ}\text{C} \pm 10^{\circ}\text{C}$ and a relative humidity of $60\%RH \pm 10\%RH$, chemical and dust free atmosphere

Even within the above guarantee periods, do not store these products in the following conditions. Otherwise, their electrical performance and/or solderability may be deteriorated, and the packaging materials (e.g. taping materials) may be deformed or deteriorated, resulting in mounting failures.

1. In salty air or in air with a high concentration of corrosive gas, such as Cl_2 , H_2S , NH_3 , SO_2 , or NO_2
2. In direct sunlight

Thick Film Chip Resistors (Terminal Lead Free)

Legal Disclaimer

The information provided in the catalog/data sheet is for the purpose of describing product specifications only, and ROYALOHM and its affiliates (hereinafter collectively referred to as "ROYALOHM") hereby disclaim any liability for any errors, inaccuracies or incompleteness contained in any product-related information (including but not limited to product specifications, datasheets, pictures, graphics). ROYALOHM reserves the right to modify this content without prior notice. Thank you for your understanding.

ROYALOHM makes no representation, warranty, and guarantee as to the fitness of its products for any particular purpose or the continuing production of any ROYALOHM products. To the maximum extent permitted by law, ROYALOHM disclaims

- (i) any and all liability arising out of the application or use of any ROYALOHM product,
- (ii) any and all liability, including without limitation special, consequential or incidental damages, and
- (iii) any and all implied warranties, including warranties of fitness for a particular purpose, non-infringement and merchantability.

ROYALOHM products are not intended for use in medical, life-saving, or life-sustaining equipment, nor are they intended for any other purpose where product failure or mismanagement could endanger life or cause harm to or death to the human body. Customers use or sell ROYALOHM products for the above purposes at their own risk. If need products for such purposes, please be sure to consult with our company to obtain relevant information about the applicable products.

Regardless of the application of ROYALOHM products, it is recommended to carry out safety tests while using measures such as protective circuits and redundant circuits to protect the safety of equipment.

New / Old Part No.

New Part.no	Old Part.no
0603WAxxxxxT5E	0603SAxxxxxT5E / 0603WGxxxxxT5E
0805W8xxxxxT5E	0805S8xxxxxT5E / 0805WAxxxxxT5E
1206W4xxxxxT5E	1206S4xxxxxT5E / 1206W8xxxxxT5E
1210W2xxxxxT5E	1210U2xxxxxT5E / 1210S3xxxxxT5E / 1210W4xxxxxT5E
181207xxxxxT4E	1812W2xxxxxT4E
201007xxxxxT4E	201034xxxxxT4E / 2010W2xxxxxT4E

Remark : The Old Part No. is still valid for the approved part.