

SWISSDIS



Swissdis AG
Grasweg 7
CH-4911 Schwarzhäusern

Tel.: +41 62 919 44 00
Fax: +41 62 919 44 01
info@swissdis.ch
www.swissdis.ch



SPECIFICATIONS

Automotive Grade Chip Resistor

CR..A-Serie

Version September 2020

Automotive Grade Chip Resistor-CR..A Series



Scope

- This specification applies to all sizes of rectangular-type fixed chip resistors with Ruthenium-base as material.

Features

- AEC-Q200 Compliance
- Highly reliable multilayer electrode construction
- Special construction to prevent sulfuration in a sulfur containing environment
- Compatible with all soldering process
- 100% CCD inspection

Construction

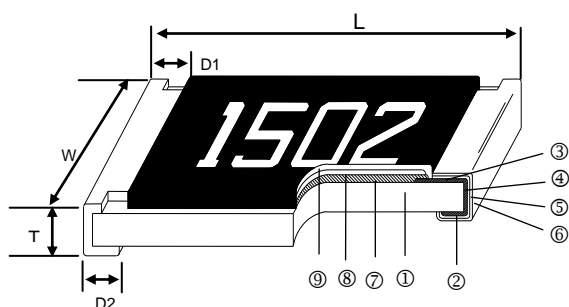

Applications

- Automotive Industry
- Telecommunication Equipments
- Radio and Tape Recorders, TV Tuners
- Digital Cameras, Watches, Pocket Calculators
- Computers, Instruments
- Medical Equipment

| | | |
|---------------------|----------------------|----------------------|
| ① Alumina Substrate | ④ Edge Electrode | ⑦ Resistor Layer |
| ② Bottom Electrode | ⑤ Barrier Layer | ⑧ Primary Overcoat |
| ③ Top Electrode | ⑥ External Electrode | ⑨ Secondary Overcoat |

Dimensions

| Type | Size (Inch) | L (mm) | W (mm) | T (mm) | D1 (mm) | D2 (mm) | Weight (g) (1000pcs) |
|-------|-------------|-----------|-----------|-----------|-----------|-----------|----------------------|
| CR-01 | 0201 | 0.60±0.03 | 0.30±0.03 | 0.23±0.03 | 0.15±0.05 | 0.15±0.05 | 0.150 |
| CR-02 | 0402 | 1.00±0.05 | 0.50±0.05 | 0.35±0.05 | 0.20±0.10 | 0.20±0.10 | 0.620 |
| CR-03 | 0603 | 1.60±0.10 | 0.80±0.10 | 0.45±0.10 | 0.30±0.20 | 0.30±0.20 | 2.042 |
| CR-05 | 0805 | 2.00±0.10 | 1.25±0.10 | 0.50±0.10 | 0.35±0.20 | 0.40±0.20 | 4.368 |
| CR-62 | 0612 | 1.55±0.10 | 3.10±0.15 | 0.55±0.10 | 0.25±0.15 | 0.35±0.15 | 9.31 |
| CR-06 | 1206 | 3.10±0.10 | 1.55±0.10 | 0.55±0.10 | 0.50±0.25 | 0.50±0.20 | 8.947 |
| CR-10 | 1210 | 3.10±0.10 | 2.60±0.15 | 0.55±0.10 | 0.50±0.25 | 0.50±0.20 | 15.959 |
| CR-0A | 2010 | 5.00±0.10 | 2.50±0.15 | 0.55±0.10 | 0.60±0.25 | 0.50±0.20 | 24.241 |
| CR-12 | 2512 | 6.35±0.10 | 3.10±0.15 | 0.55±0.10 | 0.60±0.25 | 0.50±0.20 | 39.448 |

Part Numbering

Part Number : CR-03FA7---10R

| | | | | | |
|---------------------|--|------------------------------|---|--|---|
| CR- | 03 | F | A | 7 | - - - 1 0 R |
| Product Type | Dimensions | Resistance Tolerance | Function Code | Packaging Code | Resistance |
| CR- | 01: 0201 02: 0402 03: 0603 05: 0805 62: 0612 06: 1206 10: 1210 0A: 2010 12: 2512 | D: ±0.5% F: ±1% J: ±5% | A: Automotive Grade C: High Power & Automotive Grade | 4: 7" Reel 4Kpcs 6: 7" Reel 10Kpcs 7: 7" Reel 5Kpcs 9: 10" Reel 8Kpcs A: 10" Reel 10Kpcs B: 10" Reel 20Kpcs C: 13" Reel 40Kpcs D: 13" Reel 20Kpcs | --- 1R2: 1.2Ω --- 3K3: 3.3KΩ --- 10K: 10KΩ -- 100K: 100KΩ "-" to fill up 6 spaces |

Recommend Land Pattern

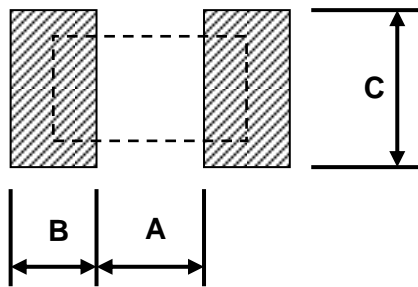

| Type | A (mm) | B (mm) | C (mm) |
|-------|--------|--------|--------|
| CR-01 | 0.30 | 0.25 | 0.30 |
| CR-02 | 0.50 | 0.45 | 0.60 |
| CR-03 | 0.90 | 0.60 | 0.90 |
| CR-05 | 1.20 | 0.70 | 1.30 |
| CR-62 | 0.70 | 1.20 | 3.20 |
| CR-06 | 2.00 | 0.90 | 1.60 |
| CR-10 | 2.00 | 0.90 | 2.80 |
| CR-0A | 3.80 | 0.90 | 2.80 |
| CR-12 | 4.90 | 1.60 | 3.50 |

Derating Curve

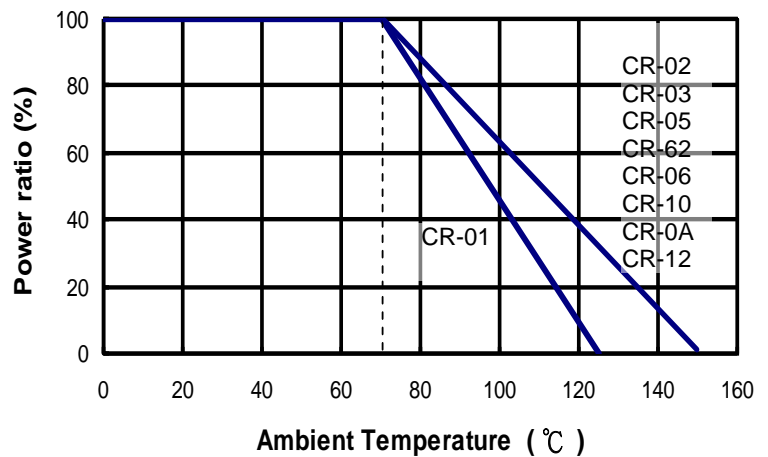

Soldering Condition

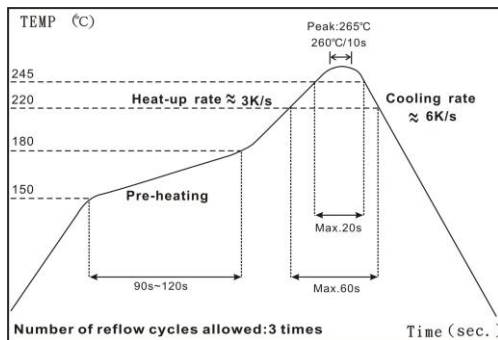

IR Reflow Soldering

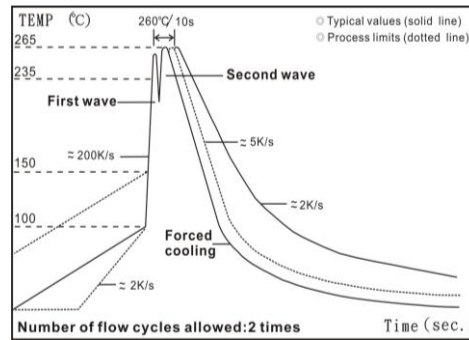

Wave Soldering (Flow Soldering)

- (1) Time of IR reflow soldering at maximum temperature point 260°C : 10s
- (2) Time of wave soldering at maximum temperature point 260°C : 10s
- (3) Time of soldering iron at maximum temperature point 410°C : 5s

Standard Electrical Specifications

| Type | Item | Power Rating at 70°C Jumper Rated Current | Operating Temp. Range | Max. Operating Voltage | Max. Overload Voltage | Resistance Range | | TCR (PPM/°C) |
|--------------|-------|---|-----------------------|------------------------|-----------------------|--|----------|----------------------|
| | | | | | | ±1%(E24 · E96) | ±5%(E24) | |
| CR-01 (0201) | 1/20W | Jumper: 1A | -55 ~ +125°C | 25V | 50V | 1Ω - 10MΩ | | ±200 |
| | - | | | | | 0Ω (<50mΩ) | - | |
| CR-02 (0402) | 1/16W | Jumper: 1A | -55 ~ +155°C | 50V | 100V | 1Ω - 9.76Ω 10Ω - 1MΩ 1.02MΩ - 10MΩ | | ±200 ±100 ±200 |
| | - | | | | | 0Ω (<50mΩ) | - | |
| CR-03 (0603) | 1/10W | Jumper: 1A | -55 ~ +155°C | 75V | 150V | 1Ω - 9.76Ω 10Ω - 1MΩ 1.02MΩ - 10MΩ | | ±200 ±100 ±200 |
| | - | | | | | 0Ω (<50mΩ) | - | |
| CR-05 (0805) | 1/8W | Jumper: 2A | -55 ~ +155°C | 150V | 300V | 1Ω - 9.76Ω 10Ω - 1MΩ 1.02MΩ - 10MΩ | | ±200 ±100 ±200 |
| | - | | | | | 0Ω (<50mΩ) | - | |
| CR-62 (0612) | 0.75W | | -55 ~ +155°C | 200V | 400V | 1Ω~9.76Ω 10Ω~1MΩ | | ±200 ±100 |
| CR-06 (1206) | 1/4W | Jumper: 2A | -55 ~ +155°C | 200V | 400V | 1Ω - 9.76Ω 10Ω - 1MΩ 1.02MΩ - 10MΩ | | ±200 ±100 ±200 |
| | - | | | | | 0Ω (<50mΩ) | - | |
| CR-10 (1210) | 1/2W | Jumper: 2.5A | -55 ~ +155°C | 200V | 400V | 1Ω - 9.76Ω 10Ω - 1MΩ 1.02MΩ - 10MΩ | | ±200 ±100 ±200 |
| | - | | | | | 0Ω (<50mΩ) | - | |
| CR-0A (2010) | 3/4W | Jumper: 3.5A | -55 ~ +155°C | 200V | 400V | 1Ω - 9.76Ω 10Ω - 1MΩ 1.02MΩ - 10MΩ | | ±200 ±100 ±200 |
| | - | | | | | 0Ω (<50mΩ) | - | |
| CR-12 (2512) | 1W | Jumper: 4A | -55 ~ +155°C | 250V | 500V | 1Ω - 9.76Ω 10Ω - 1MΩ 1.02MΩ - 10MΩ | | ±200 ±100 ±200 |
| | - | | | | | 0Ω (<50mΩ) | - | |

High Precision Electrical Specifications

| Type | Item | Power Rating at 70°C | Operating Temp. Range | Max. Operating Voltage | Max. Overload Voltage | Resistance Range (E24 · E96) | TCR (PPM/°C) |
|--------------|-------|----------------------|-----------------------|------------------------|-----------------------|------------------------------|--------------|
| | | | | | | ±0.5% | |
| CR-02 (0402) | 1/16W | -55 ~ +155°C | | 50V | 100V | 10Ω - 1MΩ | ±100 |
| CR-03 (0603) | 1/10W | | | 75V | 150V | 10Ω - 1MΩ | ±100 |
| CR-05 (0805) | 1/8W | | | 150V | 300V | 10Ω - 1MΩ | ±100 |
| CR-06 (1206) | 1/4W | | | 200V | 400V | 10Ω - 1MΩ | ±100 |
| CR-10 (1210) | 1/3W | | | 200V | 400V | 10Ω - 1MΩ | ±100 |
| CR-0A (2010) | 3/4W | | | 200V | 400V | 10Ω - 1MΩ | ±100 |
| CR-12 (2512) | 1W | | | 250V | 500V | 10Ω - 1MΩ | ±100 |

High Power Rating Electrical Specifications

| Type | Item | Power Rating at 70°C | Operating Temp. Range | Max. Operating Voltage | Max. Overload Voltage | Resistance Range | | | TCR (PPM/°C) |
|--------------|------|----------------------|-----------------------|------------------------|-----------------------|------------------|---------------|-----------|--------------|
| | | | | | | ±0.5% (E24、E96) | ±1% (E24、E96) | ±5% (E24) | |
| CR-02 (0402) | 1/8W | 1/8W | -55 ~ +155°C | 50V | 100V | - | 1Ω - 9.76Ω | | ±200 |
| | | | | | | 10Ω - 1MΩ | | | ±100 |
| CR-03 (0603) | 1/4W | 1/4W | | 75V | 150V | - | 1Ω - 9.76Ω | | ±200 |
| | | | | | | 10Ω - 1MΩ | | | ±100 |
| CR-05 (0805) | 1/3W | 1/3W | | 150V | 300V | - | 1Ω - 9.76Ω | | ±200 |
| | | | | | | 10Ω - 1MΩ | | | ±100 |
| CR-06 (1206) | 1/2W | 1/2W | | 200V | 400V | - | 1Ω - 9.76Ω | | ±200 |
| | | | 10Ω - 1MΩ | | | ±100 | | | |
| CR-0A (2010) | 1W | 1W | 200V | 400V | - | 1Ω - 9.76Ω | | ±200 | |
| | | | | | 10Ω - 1MΩ | | | ±100 | |
| CR-12 (2512) | 2W | 2W | 250V | 500V | - | 1Ω - 9.76Ω | | ±200 | |
| | | | | | 10Ω - 1MΩ | | | ±100 | |

Operating Voltage= $\sqrt{P \cdot R}$ or Max. Operating Voltage listed above, whichever is lower.

Overload Voltage= $2.5 \cdot \sqrt{P \cdot R}$ or Max. Overload Voltage listed above, whichever is lower.

The power rating depends on the maximum temperature of the resistive element. Due to the power dissipation of the resistor, the temperature of the resistive element will rise depending on the condition of heat dissipation from PCB. The maximum power rating in application only applies if the temperature of the resistive element is not exceed 155 °C.

■ Viking is capable of manufacturing the optional spec based on customer's requirement.

Temperature Rise

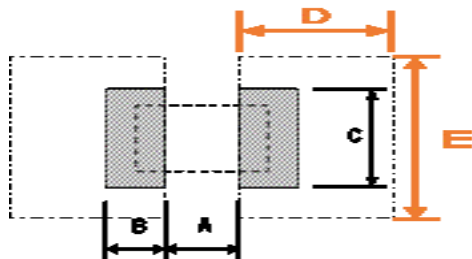
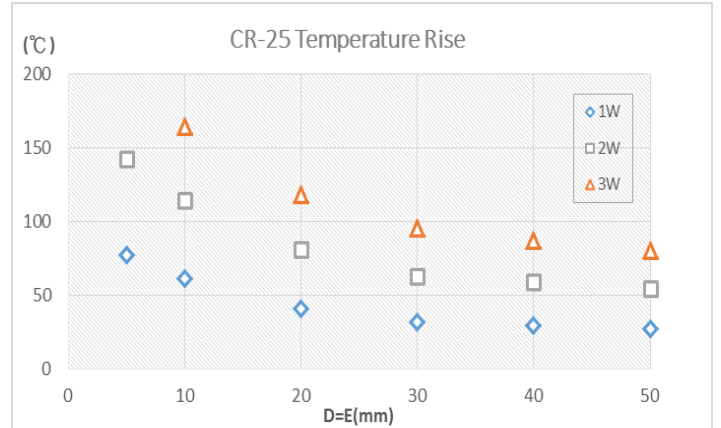
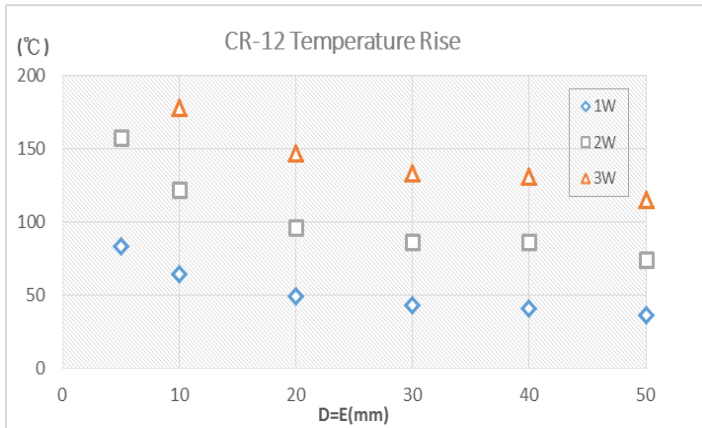

*FR4 copper board, 35μm of copper pad thickness.

Environmental Characteristics

| Item | Requirement | | | Test Method |
|--|---|---------------|--------|--|
| | ±1% and Below | ±5% | Jumper | |
| Temperature Coefficient of Resistance (T.C.R.) | As Spec. | | | JIS-C-5201-1 4.8 IEC-60115-1 4.8 At 25°C/-55°C and 25°C/+125°C, 25°C is the reference temperature |
| Short Time Overload | ±(1.0%+0.05Ω) | ±(2.0%+0.05Ω) | <50mΩ | JIS-C-5201-1 4.13 IEC-60115-1 4.13 RCWV*2.5 or Max. Overload Voltage whichever is lower for 5 seconds |
| Insulation Resistance | ≥10G | | | JIS-C-5201-1 4.6 IEC-60115-1 4.6 Max. Overload Voltage for 1 minute |
| Operational Life | ±(1.0%+0.10Ω) | ±(2.0%+0.10Ω) | <100mΩ | MIL-STD-202 Method 108 Condition D Steady State TA=125°C at derated power. Measurement at 24±4 hours after test conclusion. |
| Biased Humidity | ±(1.0%+0.10Ω) | ±(2.0%+0.10Ω) | <100mΩ | MIL-STD-202 Method 103 1000 hrs 85°C/85%RH 10% of operating power |
| High Temperature Exposure | ±(1.0%+0.05Ω) | ±(1.5%+0.10Ω) | <50mΩ | MIL-STD-202 Method 108 at +125/+155°C for 1000 hrs |
| Board Flex | ±(1.0%+0.05Ω) | ±(1.0%+0.05Ω) | <50mΩ | AEC-Q200-005 Bending once for 60 seconds 2010, 2512 sizes: 2mm Other sizes: 3mm |
| Solderability | 95% min. coverage | | | JIS-C-5201-1 4.17 IEC-60115-1 4.17 J-STD-002 245±5°C for 3 seconds |
| Resistance to Soldering Heat | ±(0.5%+0.05Ω) | ±(1.0%+0.05Ω) | <50mΩ | MIL-STD-202 Method 210 260±5°C for 10 seconds |
| Voltage Proof | No breakdown or flashover | | | JIS-C-5201-1 4.7 IEC-60115-1 4.7 1.42 times Max. Operating Voltage for 1 minute |
| Leaching | Individual leaching area ≤5% Total leaching area ≤ 10% | | | JIS-C-5201-1 4.18 IEC-60068-2-58 8.2.1 260±5°C for 30 seconds |
| Temperature Cycling | ±(0.5%+0.05Ω) | ±(1.5%+0.05Ω) | <50mΩ | JESD22 Method JA-104 -55°C to +125°C, 1000 cycles |
| Mechanical Shock | ±(0.25%+0.05Ω) | ±(1.0%+0.05Ω) | <50mΩ | MIL-STD-202 Method 213 Wave Form: Tolerance for half sine shock pulse. Peak value is 100g's. Normal duration (D) is 6. |
| Vibration | ±(0.5%+0.05Ω) | ±(1.0%+0.05Ω) | <50mΩ | MIL-STD-202 Method 204 5 g's for 20 min., 12 cycles each of 3 orientations, 10-2000 Hz |
| ESD | ±(3%+0.05Ω) | | | AEC-Q200-002 Human body model 0201: 0.5KV 0402/0603: 1KV 0805 and above: 2KV |

Automotive Grade Chip Resistor

| Item | Requirement | | | Test Method |
|------------------------|--|-----|--------|--|
| | ±1% and Below | ±5% | Jumper | |
| Resistance to Solvents | No visible damage on appearance and marking. | | | MIL-STD-202 Method 215 Add Aqueous wash chemical - OKEM Clean or equivalent. Do not use banned solvents. |
| Terminal Strength | No broken | | | AEC-Q200-006 Force of 1.8kg for 60 seconds. |
| Flammability | No ignition of the tissue paper or scorching or the pinewood board | | | UL-94 V-0 or V-1 are acceptable. Electrical test not required. |
| Sulfur Test | $\Delta R \pm 1\%$ | | <50mΩ | EIA-977 (Condition A) 60±2°C, no power rating for 480 hrs. |

RCWV(Rated Continuous Working Voltage)= $\sqrt{P \cdot R}$ or Max. Operating Voltage whichever is lower.

■ **Storage Temperature: 15~28°C; Humidity < 80%RH**

■ Packaging

Reel Specifications & Packaging Quantity

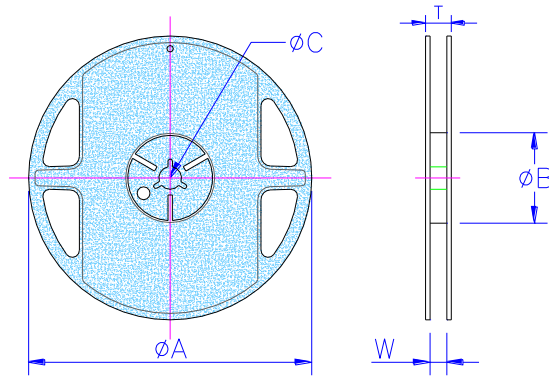

| Type | Packaging Quantity | Tape Width | Reel Diameter | ΦA (mm) | ΦB (mm) | ΦC (mm) | W (mm) | T (mm) | |
|----------------------------------|--------------------|------------|---------------|---------|-----------|---------------------|----------|----------|----------|
| CR-01 CR-02 | Paper | 10K | 8mm | 7 inch | 178.5±1.5 | 60 ^{+1/-0} | 13.0±0.2 | 9.0±0.5 | 12.5±0.5 |
| | | 20K | 8mm | 10 inch | 254±1.0 | 100±0.5 | 13.0±0.2 | 9.5±0.5 | 13.5±0.5 |
| | | 40K | 8mm | 13 inch | 330±1.0 | 100±0.5 | 13.0±0.2 | 9.5±0.5 | 13.5±0.5 |
| CR-03 CR-05 CR-06 CR-10 | Paper | 5K | 8mm | 7 inch | 178.5±1.5 | 60 ^{+1/-0} | 13.0±0.2 | 9.0±0.5 | 12.5±0.5 |
| | | 10K | 8mm | 10 inch | 254±1.0 | 100±0.5 | 13.0±0.2 | 9.5±0.5 | 13.5±0.5 |
| | | 20K | 8mm | 13 inch | 330±1.0 | 100±0.5 | 13.0±0.2 | 9.5±0.5 | 13.5±0.5 |
| CR-62 | Paper | 5K | 8mm | 7 inch | 178.5±1.5 | 60 ^{+1/-0} | 13.0±0.2 | 9.0±0.5 | 12.5±0.5 |
| CR-0A CR-12 | Embossed | 4K | 12mm | 7 inch | 178.5±1.5 | 60 ^{+1/-0} | 13.0±0.5 | 13.0±0.5 | 15.5±0.5 |
| | | 8K | 12mm | 10 inch | 250±1.0 | 62±0.5 | 13.0±0.5 | 12.5±0.5 | 16.5±0.5 |

Paper Tape Specifications

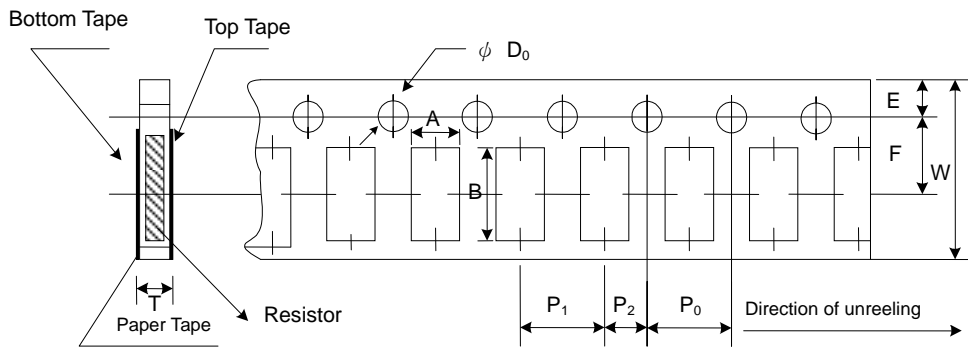

| Type | A (mm) | B (mm) | W (mm) | E (mm) | F (mm) | P ₀ (mm) | P ₁ (mm) | P ₂ (mm) | ΦD ₀ (mm) | T (mm) |
|-------|-----------|-----------|----------|-----------|-----------|---------------------|---------------------|---------------------|----------------------|-----------|
| CR-01 | 0.38±0.05 | 0.68±0.05 | 8.0±0.20 | 1.75±0.10 | 3.50±0.05 | 4.00±0.10 | 2.00±0.05 | 2.00±0.05 | 1.50+0.1,-0 | 0.42±0.20 |
| CR-02 | 0.65±0.10 | 1.15±0.10 | 8.0±0.20 | 1.75±0.10 | 3.50±0.05 | 4.00±0.10 | 2.00±0.05 | 2.00±0.05 | 1.50+0.1,-0 | 0.45±0.10 |
| CR-03 | 1.10±0.10 | 1.90±0.10 | 8.0±0.20 | 1.75±0.10 | 3.50±0.05 | 4.00±0.10 | 4.00±0.05 | 2.00±0.05 | 1.50+0.1,-0 | 0.70±0.10 |
| CR-05 | 1.60±0.10 | 2.40±0.20 | 8.0±0.20 | 1.75±0.10 | 3.50±0.05 | 4.00±0.10 | 4.00±0.05 | 2.00±0.05 | 1.50+0.1,-0 | 0.85±0.10 |
| CR-62 | 1.90±0.10 | 3.50±0.20 | 8.0±0.20 | 1.75±0.10 | 3.50±0.05 | 4.00±0.10 | 4.00±0.05 | 2.00±0.05 | 1.50+0.1,-0 | 0.85±0.10 |
| CR-06 | 1.90±0.10 | 3.50±0.20 | 8.0±0.20 | 1.75±0.10 | 3.50±0.05 | 4.00±0.10 | 4.00±0.05 | 2.00±0.05 | 1.50+0.1,-0 | 0.85±0.10 |
| CR-10 | 2.90±0.10 | 3.50±0.20 | 8.0±0.20 | 1.75±0.10 | 3.50±0.05 | 4.00±0.10 | 4.00±0.05 | 2.00±0.05 | 1.50+0.1,-0 | 0.85±0.10 |

Automotive Grade Chip Resistor

Embossed Plastic Tape Specifications

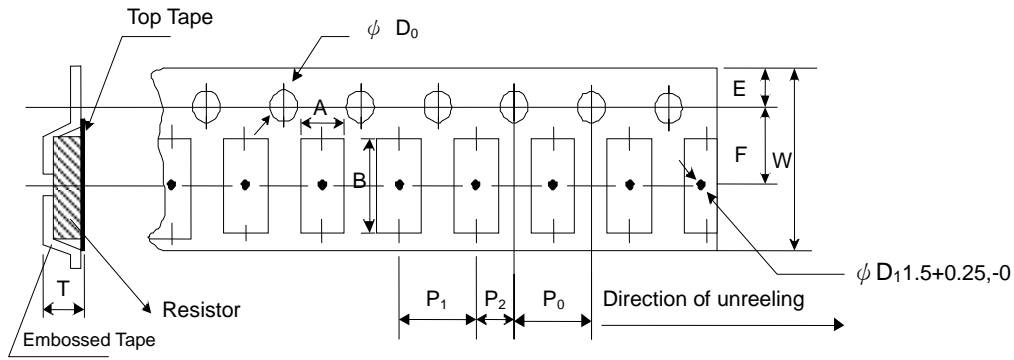

| Type | A (mm) | B (mm) | W (mm) | E (mm) | F (mm) | P ₀ (mm) | P ₁ (mm) | P ₂ (mm) | ΦD ₀ (mm) | T (mm) |
|-------|----------|----------|-----------|-----------|----------|---------------------|---------------------|---------------------|----------------------|-------------------|
| CR-0A | 2.8±0.10 | 5.5±0.10 | 12.0±0.30 | 1.75±0.10 | 5.5±0.05 | 4.00±0.10 | 4.00±0.10 | 2.00±0.05 | 1.50+0.1, -0 | 1.2 ⁺⁰ |
| CR-12 | 3.5±0.10 | 6.7±0.10 | 12.0±0.30 | 1.75±0.10 | 5.5±0.05 | 4.00±0.10 | 4.00±0.10 | 2.00±0.05 | 1.50+0.1, -0 | 1.2 ⁺⁰ |

■ Marking

No Marking for 0201/0402

Jumper for all: Letter “0”

1% for 0805/0612/1206/1210/2010/2512: 4 digits marking

Example:

| | | | | | |
|------------|------|-------|------|--------|-------|
| Resistance | 100Ω | 2.2KΩ | 10KΩ | 49.9KΩ | 100KΩ |
| Marking | 1000 | 2201 | 1002 | 4992 | 1003 |

5% for 0603/0805/0612/1206/1210/2010/2512: 3 digits marking in E24

Example: 101=100Ω 102=1KΩ (1st and 2nd are E24 code and 3rd code is multiplier)

| E24 code | 10 | 11 | 12 | 13 | 15 | 16 | 18 | 20 | 22 | 24 | 27 | 30 | 33 | 36 | 39 | 43 | 47 | 51 | 56 | 62 | 68 | 75 | 82 | 91 |
|----------|----|----|----|----|----|----|----|----|----|----|----|----|----|----|----|----|----|----|----|----|----|----|----|----|
|----------|----|----|----|----|----|----|----|----|----|----|----|----|----|----|----|----|----|----|----|----|----|----|----|----|

1% for 0603(E24): 3 digits marking in E24, When the E24 and E96 are the same resistance, this marking in E96

Example: 01A= 100Ω 05C=11KΩ 123=12KΩ 273=27KΩ

1% for 0603(E96): 3 digits marking in E96



3 digits marking for Example: 14C=13K7Ω 13C=13K3Ω
68B=4K99Ω 68X=49.9Ω

Marking Table

| Code | E96 | Code | E96 | Code | E96 | Code | E96 | | | | |
|------------|-----------------|-----------------|-----------------|-----------------|-----------------|-----------------|-----------------|------------------|------------------|--|--|
| 01 | 100 | 25 | 178 | 49 | 316 | 73 | 562 | | | | |
| 02 | 102 | 26 | 182 | 50 | 324 | 74 | 576 | | | | |
| 03 | 105 | 27 | 187 | 51 | 332 | 75 | 590 | | | | |
| 04 | 107 | 28 | 191 | 52 | 340 | 76 | 604 | | | | |
| 05 | 110 | 29 | 196 | 53 | 348 | 77 | 619 | | | | |
| 06 | 113 | 30 | 200 | 54 | 357 | 78 | 634 | | | | |
| 07 | 115 | 31 | 205 | 55 | 365 | 79 | 649 | | | | |
| 08 | 118 | 32 | 210 | 56 | 374 | 80 | 665 | | | | |
| 09 | 121 | 33 | 215 | 57 | 383 | 81 | 681 | | | | |
| 10 | 124 | 34 | 221 | 58 | 392 | 82 | 698 | | | | |
| 11 | 127 | 35 | 226 | 59 | 402 | 83 | 715 | | | | |
| 12 | 130 | 36 | 232 | 60 | 412 | 84 | 732 | | | | |
| 13 | 133 | 37 | 237 | 61 | 422 | 85 | 750 | | | | |
| 14 | 137 | 38 | 243 | 62 | 432 | 86 | 768 | | | | |
| 15 | 140 | 39 | 249 | 63 | 442 | 87 | 787 | | | | |
| 16 | 143 | 40 | 255 | 64 | 453 | 88 | 806 | | | | |
| 17 | 147 | 41 | 261 | 65 | 464 | 89 | 825 | | | | |
| 18 | 150 | 42 | 267 | 66 | 475 | 90 | 845 | | | | |
| 19 | 154 | 43 | 274 | 67 | 487 | 91 | 866 | | | | |
| 20 | 158 | 44 | 280 | 68 | 499 | 92 | 887 | | | | |
| 21 | 162 | 45 | 287 | 69 | 511 | 93 | 909 | | | | |
| 22 | 165 | 46 | 294 | 70 | 523 | 94 | 931 | | | | |
| 23 | 169 | 47 | 301 | 71 | 536 | 95 | 953 | | | | |
| 24 | 174 | 48 | 309 | 72 | 549 | 96 | 976 | | | | |
| Code | A | B | C | D | E | F | G | X | Y | | |
| Multiplier | 10 ⁰ | 10 ¹ | 10 ² | 10 ³ | 10 ⁴ | 10 ⁵ | 10 ⁶ | 10 ⁻¹ | 10 ⁻² | | |

REVISION HISTORY

| REVISION | DATE | CHANGE NOTIFICATION | DESCRIPTION |
|-----------------|--------------|----------------------------|--|
| Version A5 | Apr 30, 2015 | - | - Environmental Characteristics updated |
| Version A6 | Jun 18, 2015 | - | - Increased 0603(E24) 1% marking description |
| Version A7 | Jul 15, 2016 | - | - Remove Material Description - Size CR-01 specifications added - Modify Storage Temperature - Increased 0.5% Resistance Range - Increased High Power Rating Electrical Specifications |
| Version A8 | Jan 12, 2018 | - | - Environmental Characteristics updated - Modify Electrical Specifications (0R) - Modify 2512 Land Pattern |
| Version A9 | May 20, 2019 | - | - Modify TCR Test description - Features added 100% CCD inspection - Added Sulfur Test |
| Version B | Jun 1, 2019 | - | - Modify ESD Test description & Spec. |
| Version B1 | Oct 21, 2019 | - | - increase 2512 2W Specifications - increase Special standard packaging specifications (disc 10" & 13") |
| Version B2 | Jan 31, 2020 | - | - Features added Anti-sulfur characteristics |
| Version B3 | May 22, 2020 | - | - Added Temperature Rise - Modify High Power Rating Electrical Specifications (added 0.5%) |
| Version B4 | Sep 25, 2020 | - | - increase 0612 Specifications |