

SWISSDIS



Swissdis AG
Grasweg 7
CH-4911 Schwarzhäusern

Tel.: +41 62 919 44 00
Fax: +41 62 919 44 01
info@swissdis.ch
www.swissdis.ch



SPECIFICATIONS

Automotive Grade Thick Film Array Chip Resistor

CN..A-Serie

Version July 2024

Automotive Grade Thick Film Array Chip Resistor

Scope

– This specification applies to all sizes of rectangular-type fixed chip resistors with Ruthenium-base as material.

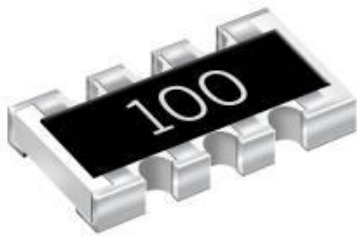

Features

- AEC-Q200 Qualified
- Small size and light weight
- Reduction of assembly costs and matching with placement machines
- Reliability, high quality
- Special construction to prevent sulfuration in a sulfur containing environment
- Suitable for IR reflow soldering
- 100% CCD inspection

Construction

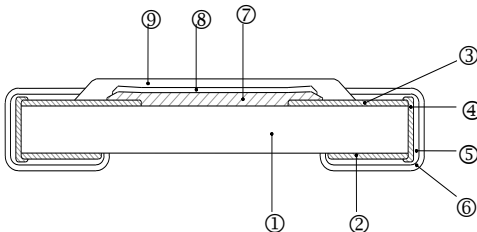

Applications

- Entertainment
- Computer & Related Products
- Communication Equipment
- Power Equipment
- Measuring Instrument

| | | |
|---------------------|----------------------|----------------------|
| ① Alumina Substrate | ④ Edge Electrode | ⑦ Resistor Layer |
| ② Bottom Electrode | ⑤ Barrier Layer | ⑧ Primary Overcoat |
| ③ Top Electrode | ⑥ External Electrode | ⑨ Secondary Overcoat |

Dimensions

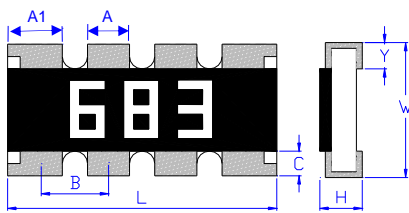

CN-42/43

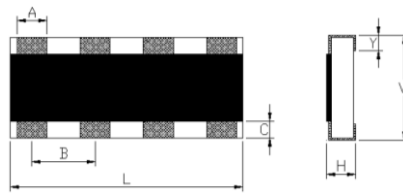

CN-41

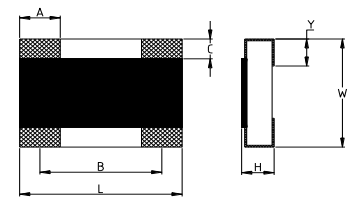

CN-21

| Type | Number of Resistors | L (mm) | W (mm) | H (mm) | A (mm) | A1 (mm) | B (mm) | C (mm) | Y (mm) | Weight (g) (1000pcs) |
|-------|---------------------|-----------|-----------|-----------|-----------|-----------|-----------|-----------|-----------|----------------------|
| CN-21 | 2 | 0.80±0.10 | 0.60±0.10 | 0.35±0.10 | 0.30±0.10 | - | 0.50±0.10 | 0.15±0.10 | 0.15±0.10 | 0.500 |
| CN-41 | 4 | 1.40±0.10 | 0.60±0.10 | 0.35±0.10 | 0.20±0.10 | - | 0.40±0.10 | 0.10±0.07 | 0.15±0.05 | 0.833 |
| CN-42 | 4 | 2.00±0.10 | 1.00±0.10 | 0.45±0.10 | 0.30±0.10 | 0.40±0.10 | 0.50±0.05 | 0.22±0.15 | 0.22±0.15 | 2.817 |
| CN-43 | 4 | 3.20±0.15 | 1.60±0.15 | 0.55±0.10 | 0.50±0.15 | 0.65±0.10 | 0.80±0.05 | 0.30±0.15 | 0.30±0.15 | 8.288 |

Part Numbering

| | | | | | |
|---------------------|--|-----------------------------|----------------------|---|---|
| CN- | 43 | J | A | 7 | - - - 1 0 R |
| Product Type | Dimensions | Resistance Tolerance | Function Code | Packaging Code | Resistance |
| CN- (Array) | 21: 0201x2 41: 0201x4 42: 0402x4 43: 0603x4 | F: ±1% J: ±5% | A: Automotive Grade | 6: 7" Reel 10Kpcs 7: 7" Reel 5Kpcs A: 10" Reel 10Kpcs B: 10" Reel 20Kpcs C: 13" Reel 40Kpcs D: 13" Reel 20Kpcs | --- 1R2: 1.2Ω --- 3K3: 3.3KΩ --- 10K: 10KΩ -- 100K: 100KΩ “-“ to fill up 6 spaces |

Derating Curve

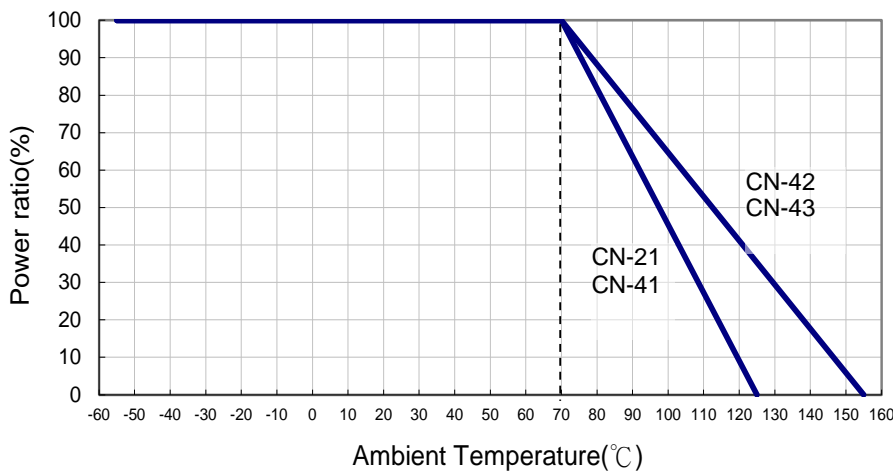

Standard Electrical Specifications

| Item Type | Power Rating at 70°C Jumper Rated Current | Operating Temp. Range | Max. Operating Voltage | Max. Overload Voltage | Number of Resistors | Resistance Range | | TCR (PPM/°C) |
|-----------|---|-----------------------|------------------------|-----------------------|---------------------|------------------|------------|--------------|
| | | | | | | ±1% | ±5% | |
| CN-21 | 1/32W | -55 ~ +125°C | 12.5V | 25V | 2 | - | 3Ω - 9.1Ω | ±300 |
| | Jumper: 0.5A | | | | | 10Ω - 1MΩ | ±200 | |
| CN-41 | 1/32W | -55 ~ +125°C | 12.5V | 25V | 2 | - | 0Ω (<50mΩ) | - |
| | Jumper: 0.5A | | | | | 10Ω - 1MΩ | ±200 | |
| CN-42 | 1/16W | -55 ~ +155°C | 25V | 50V | 4 | 10Ω - 1MΩ | 1Ω - 1MΩ | ±200 |
| | Jumper: 1A | | | | | - | 0Ω (<50mΩ) | - |
| CN-43 | 1/10W | -55 ~ +155°C | 50V | 100V | 4 | 10Ω - 1MΩ | 1Ω - 1MΩ | ±200 |
| | Jumper: 1A | | | | | - | 0Ω (<50mΩ) | - |

Operating Voltage= $\sqrt{P \cdot R}$ or Max. operating voltage listed above, whichever is lower.

Overload Voltage= $2.5 \cdot \sqrt{P \cdot R}$ or Max. overload voltage listed above, whichever is lower.

■ Viking is capable of manufacturing the optional spec based on customer's requirement.

Equivalent Circuit Diagram

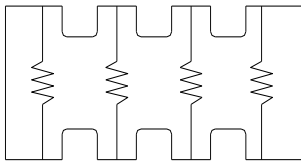

CN-42/43

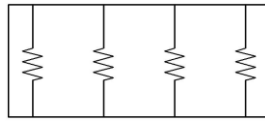

CN-41

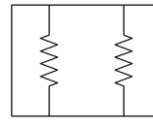

CN-21

Soldering Condition (Ref. IPC/JEDEC J-STD-020 & J-STD-002)

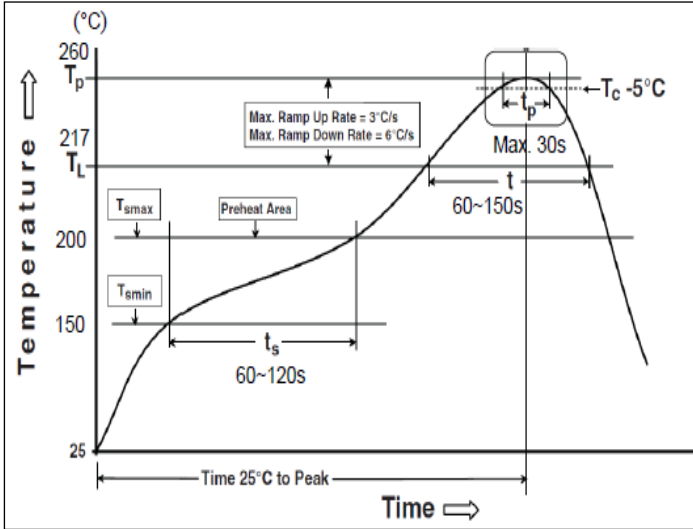

| Reflow Profiles | |
|--|------------------|
| Profile Feature | Pb-Free Assembly |
| Preheat | |
| Min. Temperature (T _{sm}) | 150 °C |
| Max Temperature (T _{sm}) | 200 °C |
| Preheating time (t _s) from (T _{sm} to T _{sm}) | 60-120 seconds |
| Ramp-up rate (T _L to T _p) | 3 °C/second max. |
| Liquidous temperature (T _L) | 217 °C |
| Time (t _L) maintained above T _L | 60-150 seconds |
| Min. Peak temperature (T _p min) | 235°C |
| Max. Peak temperature (T _p max) | 260°C |
| Time (t _p) within 5 °C of the specified classification temperature (T _c) | 30 seconds max. |
| Ramp-down rate (T _p to T _L) | 6 °C/second max. |
| Time 25 °C to peak temperature | 8 minutes max. |

Environmental Characteristics

| Item | Requirement | | | Test Method |
|--|---------------|---------------|--------|--|
| | ±1% | ±5% | Jumper | |
| Temperature Coefficient of Resistance (T.C.R.) | As Spec. | | | JIS-C-5201-1 4.8 IEC-60115-1 4.8 At 25°C/-55°C and 25°C/+125°C, 25°C is the reference temperature |
| Short Time Overload | ±(1.0%+0.05Ω) | ±(2.0%+0.05Ω) | <50mΩ | JIS-C-5201-1 4.13 IEC-60115-1 4.13 RCWV*2.5 or Max. Overload Voltage whichever is lower for 5 seconds |
| Insulation Resistance | ≥10G | | | JIS-C-5201-1 4.6 IEC-60115-1 4.6 Max. Overload Voltage for 1 minute |
| Operational Life | ±(2.0%+0.10Ω) | ±(3.0%+0.10Ω) | <100mΩ | MIL-STD-202 Method 108 Condition D Steady State TA=125°C at derated power. Measurement at 24±4 hours after test conclusion. |
| Biased Humidity | ±(2.0%+0.10Ω) | ±(3.0%+0.10Ω) | <100mΩ | MIL-STD-202 Method 103 1000 hrs 85°C/85%RH 10% of operating power (≤100V) |

| Item | Requirement | | | Test Method |
|------------------------------|--|---|------------------------------|---|
| | ±1% | ±5% | Jumper | |
| High Temperature Exposure | ±(1.0%+0.05Ω) | ±(1.5%+0.10Ω) CN-21/41: ±(3.0%+0.10Ω) | <50mΩ CN-21/41: <100mΩ | MIL-STD-202 Method 108 at +125/+155°C for 1000 hrs |
| Board Flex | ±(1.0%+0.05Ω) | ±(1.0%+0.05Ω) | <50mΩ | AEC-Q200-005 Bending once for 60 seconds with 3mm |
| Solderability | 95% min. coverage | | | JIS-C-5201-1 4.17 IEC-60115-1 4.17 J-STD-002 245±5°C for 3 seconds |
| Resistance to Soldering Heat | ±(0.5%+0.05Ω) | ±(1.0%+0.05Ω) | <50mΩ | MIL-STD-202 Method 210 260±5°C for 10 seconds |
| Voltage Proof | No breakdown or flashover | | | JIS-C-5201-1 4.7 IEC-60115-1 4.7 1.42 times Max. Operating Voltage for 1 minute |
| Leaching | Individual leaching area ≤ 5% Total leaching area ≤ 10% | | | JIS-C-5201-1 4.18 IEC-60068-2-58 8.2.1 260±5°C for 30 seconds |
| Temperature Cycling | ±(0.5%+0.05Ω) | ±(1.5%+0.05Ω) | <50mΩ | JESD22 Method JA-104 -55°C to +125°C, 1000 cycles |
| Mechanical Shock | ±(0.25%+0.05Ω) | ±(1.0%+0.05Ω) | <50mΩ | MIL-STD-202 Method 213 Wave Form: Tolerance for half sine shock pulse. Peak value is 100g's. Normal duration (D) is 6. |
| Vibration | ±(0.5%+0.05Ω) | ±(1.0%+0.05Ω) | <50mΩ | MIL-STD-202 Method 204 5 g's for 20 min., 12 cycles each of 3 orientations, 10-2000 Hz |
| ESD | ±(1%+0.05Ω) | | | AEC-Q200-002 Human body, 2KV |
| Resistance to Solvents | No visible damage on appearance and marking. | | | MIL-STD-202 Method 215 Add Aqueous wash chemical - OKEM Clean or equivalent. Do not use banned solvents. |
| Terminal Strength | No broken | | | AEC-Q200-006 Force of 1.8kg for 60 seconds. |
| Flammability | No ignition of the tissue paper or scorching or the pinewood board | | | UL-94 V-0 or V-1 are acceptable. Electrical test not required. |
| Sulfur Test | △R±1% | △R±5% | <100mΩ | EIA-977 (Condition A) 60±2°C, no power rating for 500 hrs. |

RCWV(Rated Continuous Working Voltage)=√(P*R) or Max. Operating Voltage whichever is lower.

■ **Storage Temperature: 15~28°C; Humidity < 80%RH**

■ **Shelf Life: 2 years from production date.**

■ Packaging

Reel Specifications & Packaging Quantity

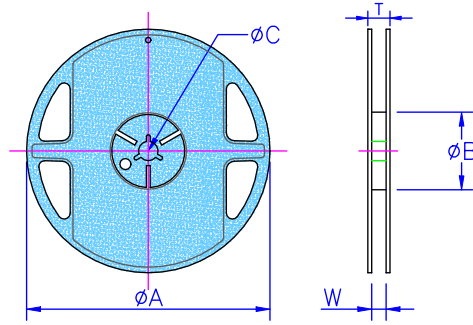

| Type | Packaging Quantity | Tape Width | Reel Diameter | ΦA (mm) | ΦB (mm) | ΦC (mm) | W (mm) | T (mm) |
|----------------|--------------------|------------|---------------|-----------|---------------------|----------|---------|----------|
| CN-21 CN-41 | Paper 10K | 8mm | 7 inch | 178.5±1.5 | 60 ^{+1/-0} | 13.0±0.2 | 9.0±0.5 | 12.5±0.5 |
| CN-42 | Paper | 10K | 7 inch | 178.5±1.5 | 60 ^{+1/-0} | 13.0±0.2 | 9.0±0.5 | 12.5±0.5 |
| | | 20K | 10 inch | 254±1.0 | 100±0.5 | 13.0±0.2 | 9.5±0.5 | 13.5±0.5 |
| | | 40K | 13 inch | 330±1.0 | 100±0.5 | 13.0±0.2 | 9.5±0.5 | 13.5±0.5 |
| CN-43 | Paper | 5K | 7 inch | 178.5±1.5 | 60 ^{+1/-0} | 13.0±0.2 | 9.0±0.5 | 12.5±0.5 |
| | | 10K | 10 inch | 254±1.0 | 100±0.5 | 13.0±0.2 | 9.5±0.5 | 13.5±0.5 |
| | | 20K | 13 inch | 330±1.0 | 100±0.5 | 13.0±0.2 | 9.5±0.5 | 13.5±0.5 |

Paper Tape Specifications

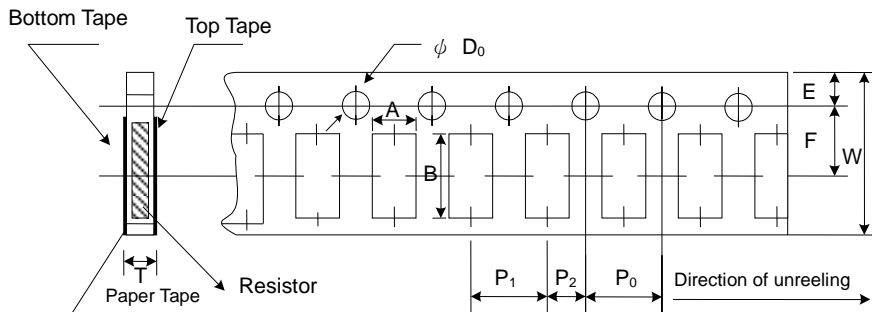

| Type | A (mm) | B (mm) | W (mm) | E (mm) | F (mm) | P ₀ (mm) | P ₁ (mm) | P ₂ (mm) | ΦD ₀ (mm) | T (mm) |
|-------|-----------|-----------|---------|----------|----------|---------------------|---------------------|---------------------|----------------------|----------|
| CN-21 | 0.77±0.05 | 0.97±0.05 | 8.0±0.2 | 1.75±0.1 | 3.5±0.05 | 4.0±0.1 | 2.0±0.05 | 2.0±0.05 | 1.50+0.1,-0 | 0.50±0.1 |
| CN-41 | 0.77±0.05 | 1.57±0.05 | 8.0±0.2 | 1.75±0.1 | 3.5±0.05 | 4.0±0.1 | 2.0±0.05 | 2.0±0.05 | 1.50+0.1,-0 | 0.50±0.1 |
| CN-42 | 1.20±0.1 | 2.20±0.1 | 8.0±0.2 | 1.75±0.1 | 3.5±0.05 | 4.0±0.1 | 2.0±0.05 | 2.0±0.05 | 1.50+0.1,-0 | 0.70±0.1 |
| CN-43 | 1.95±0.1 | 3.50±0.1 | 8.0±0.2 | 1.75±0.1 | 3.5±0.05 | 4.0±0.1 | 4.0±0.05 | 2.0±0.05 | 1.50+0.1,-0 | 0.85±0.1 |

Recommend Land Pattern

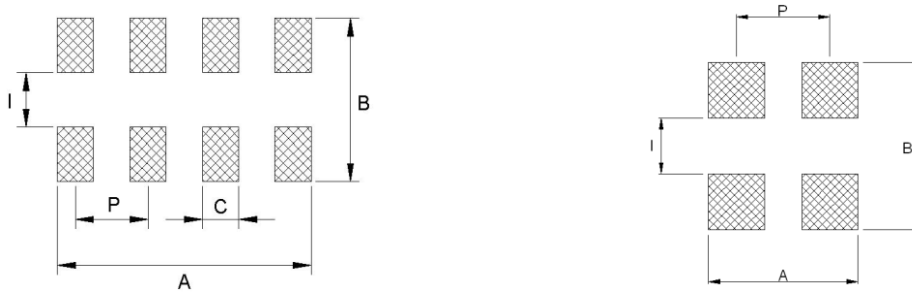

| Type | A (mm) | B (mm) | C (mm) | I (mm) | P (mm) |
|-------|--------|--------|--------|--------|--------|
| CN-21 | 0.80 | 0.90 | -- | 0.30 | 0.50 |
| CN-41 | 1.40 | 0.90 | 0.20 | 0.30 | 0.40 |
| CN-42 | 2.10 | 1.80 | 0.30 | 0.50 | 0.50 |
| CN-43 | 3.10 | 2.85 | 0.45 | 0.80 | 0.80 |

Marking

No Marking for CN-21/CN-41

Jumper for all: Letter "0"

1% for CN-42/CN-43: 4 digits marking (non-including E24 series)

Example:

| Resistance | 102Ω | 2.49KΩ | 30K1Ω | 49.9KΩ | 121KΩ |
|------------|------|--------|-------|--------|-------|
| marking | 1020 | 2491 | 3012 | 4992 | 1213 |

1% & 5% for CN-42/CN-43: 3 digits marking in E24

Example: 101=100Ω 102=1KΩ (1st and 2nd are E24 code and 3rd code is multiplier)

| E24 code | 10 | 11 | 12 | 13 | 15 | 16 | 18 | 20 | 22 | 24 | 27 | 30 | 33 | 36 | 39 | 43 | 47 | 51 | 56 | 62 | 68 | 75 | 82 | 91 |
|----------|----|----|----|----|----|----|----|----|----|----|----|----|----|----|----|----|----|----|----|----|----|----|----|----|
|----------|----|----|----|----|----|----|----|----|----|----|----|----|----|----|----|----|----|----|----|----|----|----|----|----|

REVISION HISTORY

| REVISION | DATE | CHANGE NOTIFICATION | DESCRIPTION |
|-----------------|--------------|----------------------------|--|
| Version A2 | Apr 11, 2014 | | - Recommend Land Pattern updated |
| Version A3 | Apr 30, 2015 | - | - Environmental Characteristics updated |
| Version A4 | Jun 15, 2016 | - | - Remove Material Description - Modify Storage Temperature - Increase Product Size CN-21 & CN-41 |
| Version A5 | Jan 12, 2018 | - | - Modify Electrical Specifications (0R) |
| Version A6 | May 20, 2019 | - | - Modify TCR Test description - Features added 100% CCD inspection |
| Version A7 | Oct 21, 2019 | - | - Increase Sulfur Test |
| Version A8 | Jan 31, 2020 | - | - Features added Anti-sulfur characteristics |
| Version A9 | Sep 24, 2020 | - | - Add CN-42/CN-43 Dimension A1 |
| Version B | Mar 10, 2021 | - | - Modify Soldering Condition |
| Version B1 | Nov 15, 2021 | - | - Increase the shelf life description |
| Version B2 | Feb 15, 2022 | - | - Derating Curve changes the temperature range |
| Version B3 | Jun 15, 2022 | - | - Modify Soldering Condition |
| Version B4 | Jul 08, 2024 | - | - Modify the descriptions in the Features |