

SWISSDIS



Swissdis AG
Grasweg 7
CH-4911 Schwarzhäusern

Tel.: +41 62 919 44 00
Fax: +41 62 919 44 01
info@swissdis.ch
www.swissdis.ch



SPECIFICATIONS

PSDB-Serie

Version September 2017

Shielded SMD Power Inductor

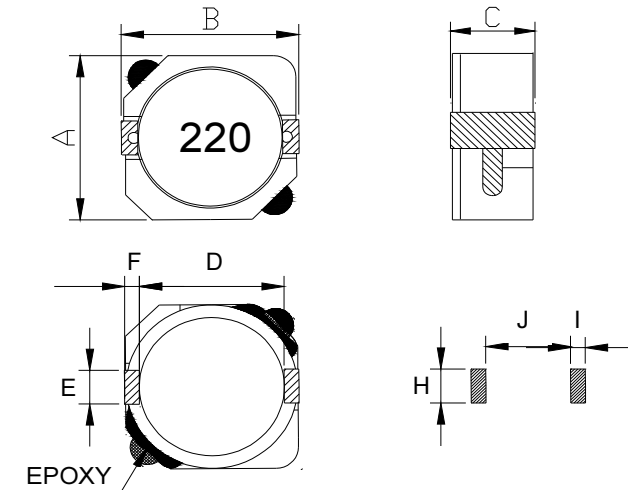

Dimensions

Unit: mm

Type	A Max.	B Max.	C Max.	D	E	F	H	I	J
PSDB5D28	6.2	6.3	3.0	4.7	2.0	0.6	2.6	1.0	4.6
PSDB1003	10.3	10.4	3.1	7.7	3.0	1.2	3.2	1.6	7.3
PSDB1004	10.3	10.4	4.0	7.7	3.0	1.2	3.2	1.6	7.3
PSDB1005	10.3	10.4	5.0	7.7	3.0	1.2	3.2	1.6	7.3

Features

- Directly connected electrode on ferrite core
- High power, High saturation inductors
- Ideal inductors for DC/DC converters
- With magnetically shielded against radiation
- Available on tape and reel for automatic surface mounting.

Inductance and rated current ranges

- PSDB5D28 1.0~100μH 2.90~0.40A
- PSDB1003 0.56~1000μH 6.20~0.23A
- PSDB1004 0.56~1000μH 10.0~0.32A
- PSDB1005 1.5~1000μH 10.5~0.35A

- Test equipment:
L: HP4284A LCR meter
DCR: Milli-ohm meter
- Electrical specifications at 25°C

Applications

- Power Supply for VTRs
- LCD Televisions
- Notebook PCs
- Portable Communication
- DC/DC Converters, etc.

Characteristics

- Rated DC current: The current when the inductance becomes 35% lower than its initial value or the actual current when the temperature of coil increases to $\Delta T=40^{\circ}C$. The smaller one is defined as Rated DC Current. ($T_a=25^{\circ}C$)
- Operating temperature range: $-40\sim 125^{\circ}C$

Product Identification

PSDB	5D28	N	T	101
Product Type	Dimensions (AxBxC)	Inductor Tolerance	Packaging Style	Inductance
	5D28: 6.2×6.3×3.0 1003: 10.3×10.4×3.1 1004: 10.3×10.4×4.0 1005: 10.3×10.4×5.0	M: ±20% N: ±30%	T: Tape and Reel	1R0: 1.0μH 470: 47μH 101: 100μH

■Electrical Characteristics

PSDB5D28 Type(□:Tolerance):

Part No	L (μ H)	Tolerance	Test Condition	DCR (m Ω) max.	IDC (A) max.
PSDB5D28□T1R0	1.0	N	100KHz, 0.1V	15.0	2.90
PSDB5D28□T1R5	1.5	N	100KHz, 0.1V	16.0	2.80
PSDB5D28□T2R2	2.2	N	100KHz, 0.1V	17.0	2.70
PSDB5D28□T2R5	2.5	N	100KHz, 0.1V	17.6	2.60
PSDB5D28□T3R3	3.3	N	100KHz, 0.1V	20.3	2.30
PSDB5D28□T4R0	4.0	N	100KHz, 0.1V	27.0	2.10
PSDB5D28□T4R7	4.7	N	100KHz, 0.1V	29.0	2.00
PSDB5D28□T5R0	5.0	N	100KHz, 0.1V	31.1	1.85
PSDB5D28□T6R0	6.0	N	100KHz, 0.1V	41.9	1.70
PSDB5D28□T6R2-1	6.2	M	100KHz, 0.25V	74	1.49
PSDB5D28□T8R0	8.0	N	100KHz, 0.1V	49.9	1.50
PSDB5D28□T8R2-1	8.2	M	100KHz, 0.25V	102	1.25
PSDB5D28□T100	10	N	100KHz, 0.1V	54.0	1.30
PSDB5D28□T100-1	10	M	100KHz, 0.25V	118	1.22
PSDB5D28□T120	12	N	100KHz, 0.1V	71.6	1.20
PSDB5D28□T150	15	N	100KHz, 0.1V	82.4	1.10
PSDB5D28□T150-1	15	M	100KHz, 0.25V	179	0.94
PSDB5D28□T180	18	N	100KHz, 0.1V	101.5	1.05
PSDB5D28□T220	22	N	100KHz, 0.1V	119.0	0.95
PSDB5D28□T220-1	22	M	100KHz, 0.25V	253	0.80
PSDB5D28□T270	27	N	100KHz, 0.1V	146.0	0.85
PSDB5D28□T330	33	N	100KHz, 0.1V	182.5	0.76
PSDB5D28□T330-1	33	M	100KHz, 0.25V	368	0.63
PSDB5D28□T390	39	N	100KHz, 0.1V	209.5	0.68
PSDB5D28□T470	47	N	100KHz, 0.1V	229.5	0.60
PSDB5D28□T470-1	47	M	100KHz, 0.25V	542	0.50
PSDB5D28□T560	56	N	100KHz, 0.1V	305.0	0.55
PSDB5D28□T680	68	N	100KHz, 0.1V	351.0	0.48
PSDB5D28□T820	82	N	100KHz, 0.1V	418.5	0.45
PSDB5D28□T101	100	N	100KHz, 0.1V	520.0	0.40

■Electrical Characteristics

PSDB1003 Type(□:Tolerance):

Part No	L (μ H)	Tolerance	Test Condition	DCR (m Ω) max.	IDC (A) max.
PSDB1003□TR56	0.56	N	100KHz, 0.1V	20	6.20
PSDB1003□T1R0	1.0	N	100KHz, 0.1V	20	6.20
PSDB1003□T1R2	1.2	N	100KHz, 0.1V	20	6.20
PSDB1003□T1R3	1.3	N	100KHz, 0.1V	20	6.20
PSDB1003□T1R5	1.5	N	100KHz, 0.1V	20	6.20
PSDB1003□T1R8	1.8	N	100KHz, 0.1V	23	5.60
PSDB1003□T2R2	2.2	N	100KHz, 0.1V	23	5.60
PSDB1003□T2R5	2.5	N	100KHz, 0.1V	23	5.60
PSDB1003□T2R7	2.7	N	100KHz, 0.1V	23	5.60
PSDB1003□T3R3	3.3	N	100KHz, 0.1V	29	5.00
PSDB1003□T3R8	3.8	N	100KHz, 0.1V	29	5.00
PSDB1003□T4R0	4.0	N	100KHz, 0.1V	33	4.80
PSDB1003□T4R7	4.7	N	100KHz, 0.1V	35	4.83
PSDB1003□T5R0	5.0	N	100KHz, 0.1V	35	4.83
PSDB1003□T5R2	5.2	N	100KHz, 0.1V	43	4.83
PSDB1003□T8R2	8.2	N	100KHz, 0.1V	50	3.54
PSDB1003□T100	10	M, N	100KHz, 0.1V	58	2.70
PSDB1003□T120	12	M, N	100KHz, 0.1V	72	2.25
PSDB1003□T150	15	M, N	100KHz, 0.1V	86	2.22
PSDB1003□T180	18	M, N	100KHz, 0.1V	116	1.90
PSDB1003□T220	22	M, N	100KHz, 0.1V	145	1.78
PSDB1003□T270	27	M, N	100KHz, 0.1V	176	1.63
PSDB1003□T330	33	M, N	100KHz, 0.1V	213	1.46
PSDB1003□T390	39	M, N	100KHz, 0.1V	270	1.32
PSDB1003□T470	47	M, N	100KHz, 0.1V	299	1.18
PSDB1003□T560	56	M, N	100KHz, 0.1V	335	1.10
PSDB1003□T680	68	M, N	100KHz, 0.1V	451	1.04
PSDB1003□T820	82	M, N	100KHz, 0.1V	513	0.94
PSDB1003□T101	100	M, N	100KHz, 0.1V	700	0.84
PSDB1003□T121	120	M, N	100KHz, 0.1V	765	0.76
PSDB1003□T151	150	M, N	100KHz, 0.1V	876	0.70
PSDB1003□T181	180	M, N	100KHz, 0.1V	1000	0.60
PSDB1003□T221	220	M, N	100KHz, 0.1V	1050	0.58
PSDB1003□T271	270	M, N	100KHz, 0.1V	1500	0.56
PSDB1003□T331	330	M, N	100KHz, 0.1V	1800	0.52
PSDB1003□T391	390	M, N	100KHz, 0.1V	2000	0.50
PSDB1003□T471	470	M, N	100KHz, 0.1V	2170	0.48
PSDB1003□T561	560	M, N	100KHz, 0.1V	2750	0.35
PSDB1003□T681	680	M, N	100KHz, 0.1V	3200	0.29
PSDB1003□T821	820	M, N	100KHz, 0.1V	3800	0.28
PSDB1003□T102	1000	M, N	100KHz, 0.1V	5000	0.23

Shielded SMD Power Inductor

Electrical Characteristics

PSDB1004 Type(□:Tolerance):

Part No	L (μ H)	Tolerance	Test Condition	DCR (m Ω) max.	IDC (A) max.
PSDB1004□TR56	0.56	N	100KHz, 0.1V	8	10.0
PSDB1004□T1R0	1.0	N	100KHz, 0.1V	8	10.0
PSDB1004□T1R2	1.2	N	100KHz, 0.1V	8	10.0
PSDB1004□T1R3	1.3	N	100KHz, 0.1V	8	10.0
PSDB1004□T1R5	1.5	N	100KHz, 0.1V	8	10.0
PSDB1004□T1R8	1.8	N	100KHz, 0.1V	10	9.5
PSDB1004□T2R2	2.2	N	100KHz, 0.1V	11	8.00
PSDB1004□T2R5	2.5	N	100KHz, 0.1V	12	7.50
PSDB1004□T2R7	2.7	N	100KHz, 0.1V	12	7.50
PSDB1004□T3R3	3.3	N	100KHz, 0.1V	13	6.50
PSDB1004□T3R8	3.8	N	100KHz, 0.1V	17	6.00
PSDB1004□T4R7	4.7	N	100KHz, 0.1V	21	5.70
PSDB1004□T5R0	5.0	N	100KHz, 0.1V	22	5.60
PSDB1004□T5R2	5.2	N	100KHz, 0.1V	22	5.50
PSDB1004□T5R6	5.6	M, N	100KHz, 0.1V	25	5.20
PSDB1004□T6R8	6.8	M, N	100KHz, 0.1V	26	4.90
PSDB1004□T7R0	7.0	M, N	100KHz, 0.1V	27	4.80
PSDB1004□T8R2	8.2	M, N	100KHz, 0.1V	33	4.60
PSDB1004□T100	10	M, N	100KHz, 0.1V	35	4.40
PSDB1004□T120	12	M, N	100KHz, 0.1V	46	3.92
PSDB1004□T150	15	M, N	100KHz, 0.1V	50	3.60
PSDB1004□T180	18	M, N	100KHz, 0.1V	70	3.00
PSDB1004□T220	22	M, N	100KHz, 0.1V	73	2.90
PSDB1004□T270	27	M, N	100KHz, 0.1V	83	2.80
PSDB1004□T330	33	M, N	100KHz, 0.1V	93	2.30
PSDB1004□T390	39	M, N	100KHz, 0.1V	120	2.20
PSDB1004□T470	47	M, N	100KHz, 0.1V	128	2.10
PSDB1004□T560	56	M, N	100KHz, 0.1V	171	1.80
PSDB1004□T680	68	M, N	100KHz, 0.1V	213	1.50
PSDB1004□T820	82	M, N	100KHz, 0.1V	250	1.40
PSDB1004□T101	100	M, N	100KHz, 0.1V	304	1.35
PSDB1004□T121	120	M, N	100KHz, 0.1V	400	1.20
PSDB1004□T151	150	M, N	100KHz, 0.1V	506	1.15
PSDB1004□T181	180	M, N	100KHz, 0.1V	631	1.03
PSDB1004□T221	220	M, N	100KHz, 0.1V	756	0.92
PSDB1004□T271	270	M, N	100KHz, 0.1V	853	0.84
PSDB1004□T331	330	M, N	100KHz, 0.1V	1090	0.70
PSDB1004□T391	390	M, N	100KHz, 0.1V	1450	0.62
PSDB1004□T471	470	M, N	100KHz, 0.1V	1520	0.54
PSDB1004□T561	560	M, N	100KHz, 0.1V	2500	0.50
PSDB1004□T681	680	M, N	100KHz, 0.1V	2800	0.45
PSDB1004□T821	820	M, N	100KHz, 0.1V	3000	0.40
PSDB1004□T102	1000	M, N	100KHz, 0.1V	3250	0.32

Shielded SMD Power Inductor

Electrical Characteristics

PSDB1005 Type(□:Tolerance):

Part No	L (μ H)	Tolerance	Test Condition	DCR (m Ω) max.	IDC (A) max.
PSDB1005□T1R5	1.5	N	100KHz, 0.1V	6	10.5
PSDB1005□T2R2	2.2	N	100KHz, 0.1V	7	9.25
PSDB1005□T3R3	3.3	N	100KHz, 0.1V	10	7.80
PSDB1005□T4R7	4.7	N	100KHz, 0.1V	12	6.40
PSDB1005□T6R8	6.8	N	100KHz, 0.1V	18	5.40
PSDB1005□T8R2	8.2	N	100KHz, 0.1V	20	4.85
PSDB1005□T100	10	M, N	100KHz, 0.1V	26	3.45
PSDB1005□T120	12	M, N	100KHz, 0.1V	33	3.40
PSDB1005□T150	15	M, N	100KHz, 0.1V	41	2.83
PSDB1005□T180	18	M, N	100KHz, 0.1V	46	2.62
PSDB1005□T220	22	M, N	100KHz, 0.1V	61	2.44
PSDB1005□T270	27	M, N	100KHz, 0.1V	69	2.24
PSDB1005□T330	33	M, N	100KHz, 0.1V	84	1.88
PSDB1005□T390	39	M, N	100KHz, 0.1V	106	1.70
PSDB1005□T470	47	M, N	100KHz, 0.1V	130	1.56
PSDB1005□T560	56	M, N	100KHz, 0.1V	149	1.39
PSDB1005□T680	68	M, N	100KHz, 0.1V	201	1.36
PSDB1005□T820	82	M, N	100KHz, 0.1V	227	1.20
PSDB1005□T101	100	M, N	100KHz, 0.1V	253	1.09
PSDB1005□T101-1	100	M	100KHz, 0.1V	253	1.35
PSDB1005□T121	120	M, N	100KHz, 0.1V	303	1.00
PSDB1005□T151	150	M, N	100KHz, 0.1V	370	0.91
PSDB1005□T181	180	M, N	100KHz, 0.1V	419	0.84
PSDB1005□T221	220	M, N	100KHz, 0.1V	500	0.75
PSDB1005□T271	270	M, N	100KHz, 0.1V	672	0.68
PSDB1005□T331	330	M, N	100KHz, 0.1V	812	0.60
PSDB1005□T391	390	M, N	100KHz, 0.1V	953	0.57
PSDB1005□T471	470	M, N	100KHz, 0.1V	1289	0.50
PSDB1005□T561	560	M, N	100KHz, 0.1V	1430	0.47
PSDB1005□T681	680	M, N	100KHz, 0.1V	1599	0.43
PSDB1005□T821	820	M, N	100KHz, 0.1V	1768	0.39
PSDB1005□T102	1000	M, N	100KHz, 0.1V	1989	0.35

Shielded SMD Power Inductor

■Tape and Reel specifications

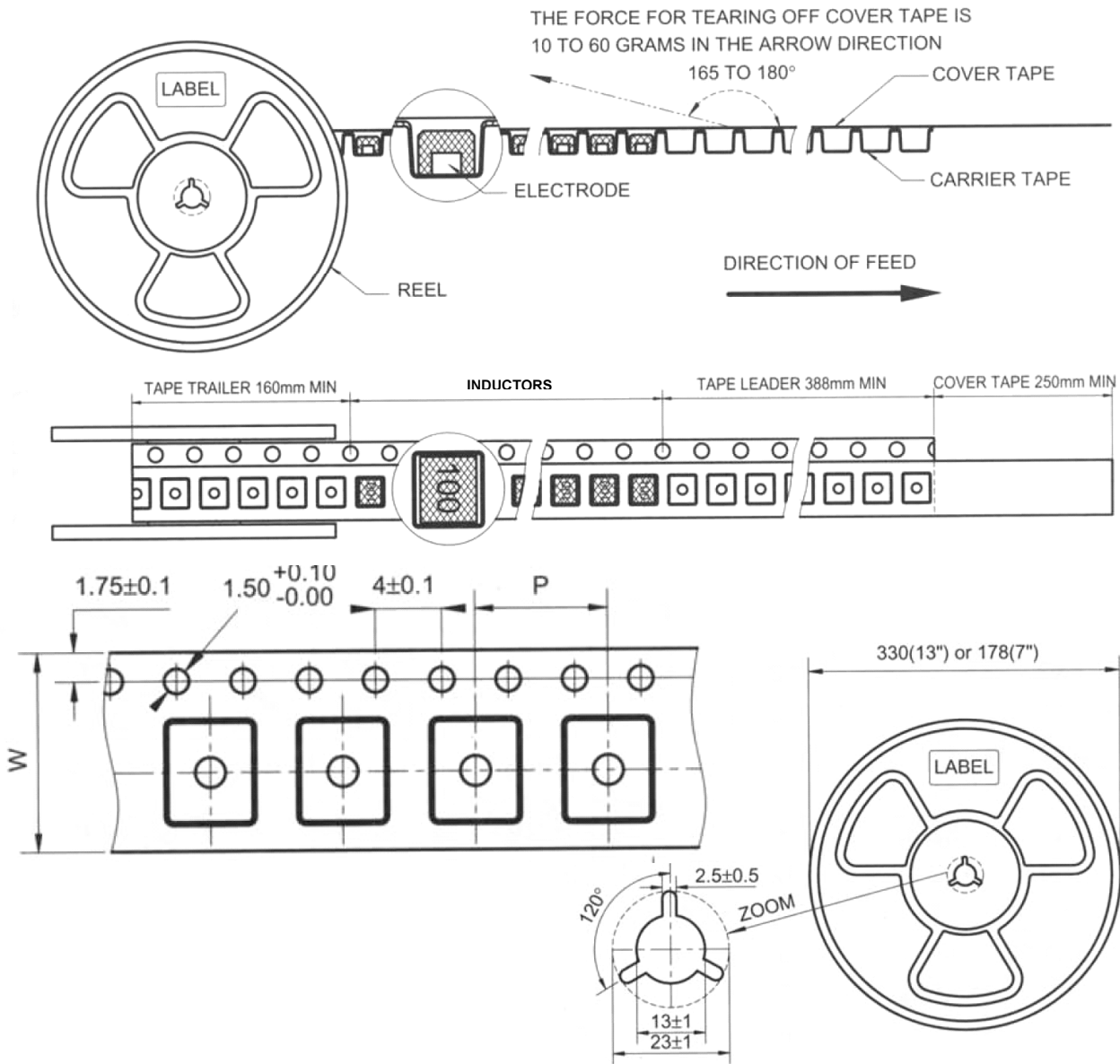

Unit:mm

Type	Tape size		Parts Per Reel
	W	P	13"
PSDB5D28	12	8	2000
PSDB1003	24	16	1000
PSDB1004	24	16	750
PSDB1005	24	16	750

Shielded SMD Power Inductor

■ SMD Power Inductor Environmental Specifications

General

Items	Specifications
Shelf Storage conditions	Temperature range: 15~28°C; Humidity: <80% relative humidity. Recommended product should be used within one year from the time of delivery.

Environmental test

Test Items	Specifications	Test Conditions / Test Methods
High temperature Storage test	No case deformation or change in appearance. $\Delta L/L \leq 10\%$	Temperature 85±2°C, Time: 48±2 hours, Tested after 1 hour at room temperature.
Low temperature Storage test		Temperature -40±2°C, Time: 48±2 hours, Tested after 1 hour at room temperature.
Humidity test		Temperature 40±2°C, 90~95% relative humidity Time: 96±2 hours Tested after 1 hour at room temperature.
Thermal shock test		First -25°C 30minutes then 25°C 10 minutes last 85°C 30 minutes, as 1 cycle. Go through 5 cycles. Tested after 1 hour at room temperature.

Mechanical test

Test Items	Specifications	Test Conditions / Test Methods
Solderability test	Terminal area must have 90% minimum solder coverage.	Product with Lead-free terminal: Dip pads in flux then dip in solder pot at 245±5°C for 3 seconds.
Resistance to Soldering Heat	No case deformation or change in appearance.	Flux should cover the whole of the sample before heating, then be preheated for about 2 minutes over temperature of 130~150°C. Immersing to 260±5°C for 10 seconds.
Vibration test	No case deformation or change in appearance. $\Delta L/L \leq 10\%$	Apply frequency 10~55Hz. 1.5mm amplitude in each of perpendicular direction for 2 hours.
Shock resistance		Drop down with 981m/s ² (100G) shock attitude upon a rubber block method shock testing machine, for 1 time. In each of three orientations.

The condition of reflow (recommendation):

