

**SWISSDIS**



Swissdis AG  
Grasweg 7  
CH-4911 Schwarzhäusern

Tel.: +41 62 919 44 00  
Fax: +41 62 919 44 01  
[info@swissdis.ch](mailto:info@swissdis.ch)  
[www.swissdis.ch](http://www.swissdis.ch)



# SPECIFICATIONS

## SD12864-FTRE-12-W

Swissdis 108553

LCD Module Graphic 128x64 Dots  
With LED Backlight white

Version August 2013

**REVISION RECORD (MODEL NO.: GY1206120498FSWCQ01)**

<b>Revision</b>	<b>Revision Date</b>	<b>Page</b>	<b>Contents</b>
A	2013/05/15		Initial Release and Issue Full Specification.
B	2013/08/15		Change the Backlight.
C	2014/02/24		Change the Outline(Add Data Code).



# CONTENTS

※ CONTENTS

1. FEATURES
2. MECHANICAL SPECIFICATIONS
3. ELECTRICAL SPECIFICATIONS
4. POWER SUPPLY AND BLOCK DIAGRAM
5. ELECTRO-OPTICAL CHARACTERISTICS
6. TERMINAL FUNCTIONS
7. AC CHARACTERISTICS
8. INSTRUCION DESCRIPTION
9. QUALITY SPECIFICATIONS
10. RELIABILITY
11. HANDLING PRECAUTIONS
12. OUTLINE DIMENSION

- ※ 1. SAMPLES OUTGOING INSPECTION REPORT  
2. REVISION RECORD

MODEL	GY1206120498FSWCQ01	1/20	PRODUCT SPECIFICATIONS	REV: C
-------	---------------------	------	------------------------	--------

## 1. FEATURES

The features of LCD are as follows

- \* Display mode : FSTN, Positive, Transflective
- \* Color : Display dot : Black  
Background: White
- \* Display Format : 128 X 64 Dots
- \* IC : Ultra Chip: UC1601x GAD
- \* Interface Input Data : Serial and parallel Interface MPU
- \* Driving Method : 1/65 Duty, 1/9 Bias
- \* Viewing Direction : 12 O'clock
- \* Backlight : LED(White)
- \* LCM technological conditions: **RoHS**

## 2. MECHANICAL SPECIFICATIONS

Item	Specification	Unit
Module Size	79.2(W) x 140.25(H) x 5.5MAX(T)	mm
Viewing Area	70.7MIN(W) x 38.8MIN(H)	mm
Effective Display Area	66.54(W) x 33.26(H)	mm
Character Font	128 x 64 Dots	-
Dot Size	0.50(W) X 0.50(H)	mm
Dot Pitch	0.52(W) X 0.52(H)	mm

## 3. ELECTRICAL SPECIFICATIONS

### 3-1. Absolute Maximum Ratings (V<sub>SS</sub>=0V)

Item	Symbol	Standard Value			Unit
		Min.	Typ.	Max.	
Supply Voltage For Logic	V <sub>DD</sub>	-0.3	-	+4.0	V
Supply Voltage For LCD Drive	V <sub>LCD</sub>	-0.3	-	+12.0	V
Input Voltage	V <sub>IN</sub>	-0.4	-	V <sub>DD</sub> +0.3	V
Operating Temp.	T <sub>OP</sub>	-20	-	+70	°C
Storage Temp.	T <sub>ST</sub>	-30	-	+80	°C

MODEL	GY1206120498FSWCQ01	2/20	PRODUCT SPECIFICATIONS	REV: C
-------	---------------------	------	------------------------	--------

### 3. ELECTRICAL SPECIFICATIONS (Continued)

#### 3-2. Electrical Characteristics (V<sub>SS</sub>=0V)

Item	Symbol	Test Condition	Min.	Typ.	Max.	Unit
Logic Supply Voltage	V <sub>DD</sub> - V <sub>SS</sub>	Ta=0~50°C	2.4	3.0	3.3	V
LCD Drive Voltage (Recommended Voltage)	V <sub>OP</sub> =V <sub>LCD</sub> -V <sub>SS</sub>	Ta=25°C	8.7	9.0	9.3	V
Input Voltage	"H" Level	V <sub>DD</sub> =3.0V±5%	0.8V <sub>DD</sub>	-	-	V
	"L" Level		-	-	0.2V <sub>DD</sub>	V
Output Voltage	"H" Level	V <sub>DD</sub> =3.0V±5%	0.8V <sub>DD</sub>	-	-	V
	"L" Level		-	-	0.2V <sub>DD</sub>	V
Current Consumption	I <sub>DD</sub>	V <sub>DD</sub> =3.0V±5% V <sub>LCD</sub> -V <sub>SS</sub> =9.0V	-	0.50	1.0	mA

NOTE: 1) Duty Ratio=1/65, Bias Ratio=1/9

2) Measuring in Dots ON-state

#### 3-3. Backlight

##### 3-3-1. Absolute Maximum Ratings at Ta=25°C

Item	Symbol	Rating	Unit
Peak Forward Current	IFM	112.5	mA
Reverse Voltage	VR	5.0	V
Power Dissipation	Po	382.5	mW
Storage Temperature Range	Tstg	-30~+80	°C
Hand Soldering Temperature	260°C for 3 seconds		-

##### 3-3-2. Electronic Optical Characteristics (If=75mA)

Item	Symbol	Min.	Typ.	Max	Unit
Forward Voltage	V <sub>F</sub>	2.8	3.0	3.4	V
Luminous Intensity	I <sub>v</sub>	1200	1800	2500	cd/m <sup>2</sup>
Uniformity	U	70	-	-	%
AVG. X OF 1931 C.I.E	X	0.26	0.29	0.32	-
AVG. Y OF 1931 C.I.E	Y	0.25	0.28	0.31	-

\* The brightness is measured without LCD panel

<b>MODEL</b>	<b>GY1206120498FSWCQ01</b>	<b>3/20</b>	<b>PRODUCT SPECIFICATIONS</b>	<b>REV: C</b>
--------------	----------------------------	-------------	-------------------------------	---------------

## 4. BLOCK DIAGRAM

### 4-1. IC Reference circuit using internal HV generator circuit

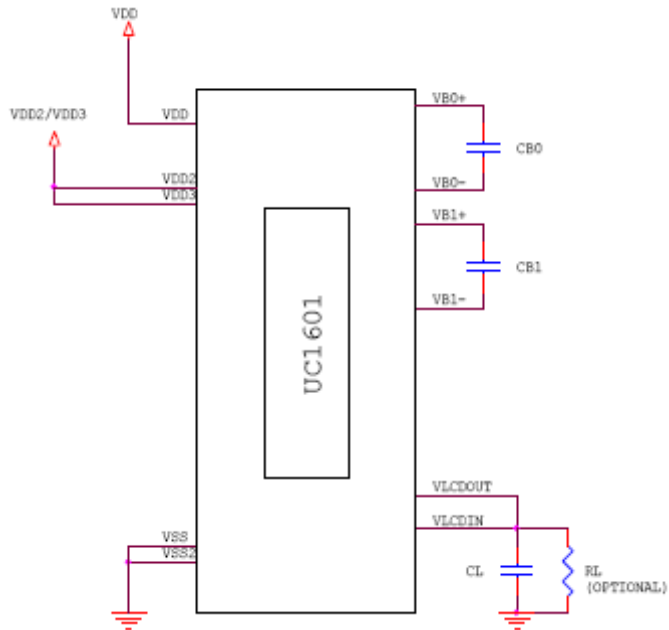

#### Note

- Recommended component values:
  - $C_B$ :  $100\times\sim 200\times$  LCD load capacitance or  $1.0\mu\text{F}$  (2V), whichever is higher.
  - $C_L$ :  $10\text{nF} \sim 30\text{nF}$  (25V) is appropriate for most applications.
  - $R_L$ :  $10\text{M}\Omega$ . Acts as a draining circuit when the power is abnormally shut down.

### 4-2. Backlight circuit diagram

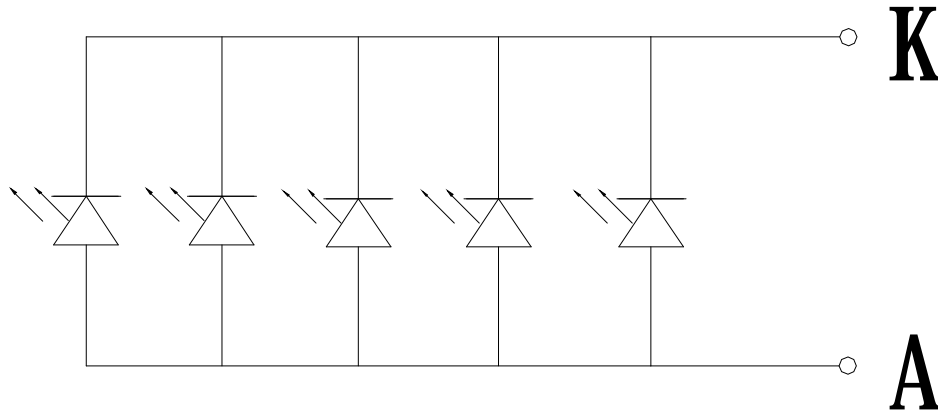

## 5. ELECTRO – OPTICAL CHARACTERISTICS

Item	Symbol	Temp.	Min.	Typ.	Max.	Unit	Conditions	Note
Viewing Angle $Cr \geq 2$	$\Phi=0^\circ$	25°C	--	28	--	Deg.	-	1,2
	$\Phi=180^\circ$		--	32	--			
	$\Phi=90^\circ$		--	32	--			
	$\Phi=270^\circ$		--	33	--			
Viewing Direction		12 O'clock						
Contrast Ratio	Cr	25°C	2.0	5.16	5.88	-	$\Theta = 0^\circ$ $\Phi = 0^\circ$	3
Response Time(rise)	Tr	25°C	-	141	250	ms	$\Theta = 0^\circ$ $\Phi = 0^\circ$	4
		0°C	-	950	1150			
Response Time(fall)	Tf	25°C	-	198	250	ms	$\Theta = 0^\circ$ $\Phi = 0^\circ$	4
		0°C	-	950	1150			

Note1. Definition of Angle  $\Theta Y1$  &  $\Theta Y2$

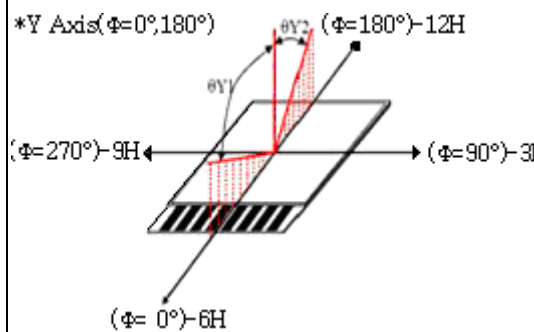

Note2. Definition of Viewing Angle  $\Theta X1$  &  $\Theta X2$

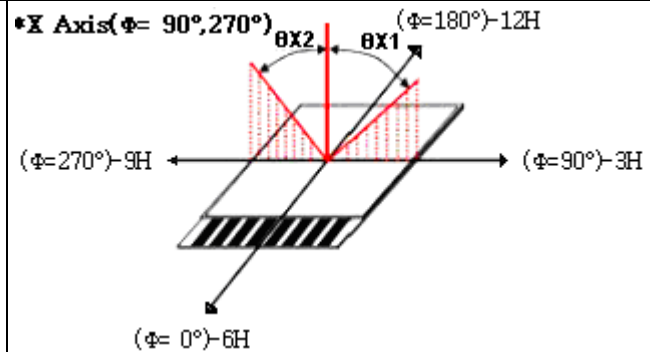

Note3. Definition of Contrast Cr

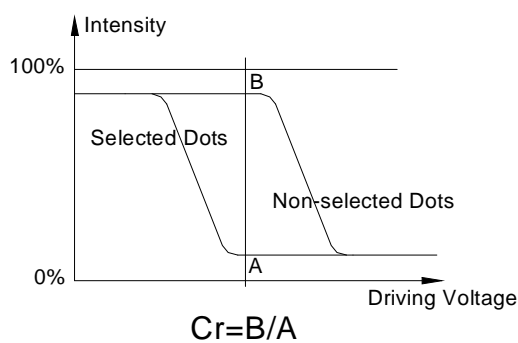

Note4. Definition of Optical Response

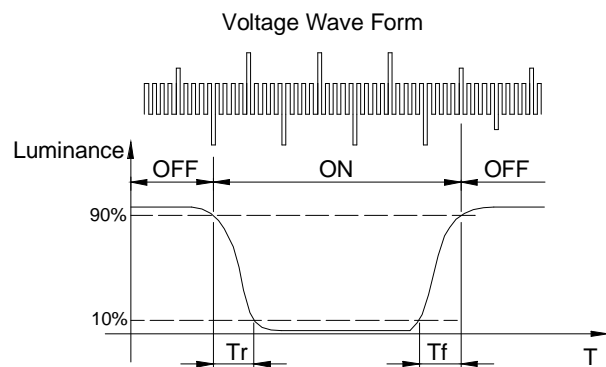

MODEL

GY1206120498FSWCQ01

5/20

PRODUCT SPECIFICATIONS

REV: C

## 6. TERMINAL PIN FUNCTION

Pin NO.	Symbol	I / O	Functions
1	/CS	I	Chip Select or chip address.
2	/RST	I	When RST="L", all control registers are re-initialized by their default states.
3	CD	I	Select the incoming command if it is a control instruction or for display data.
4	WR0	I	WR[1:0]controls the read/write operation of the host interface. See Host Interface section for details. The meaning of WR[1:0] depends on whether the interface is In the 6800 mode, or the 8080 mode. In serial modes, these two pins are not used and can be connected to Vss
5	WR1		
6	D0(SCK)	I/O	Bi-directional bus for both serial and parallel host interfaces
7~8	D1~D2		
9	D3(SDA)		
10~13	D4~D7		
14	BM0	I	Bus mode:"HL":8080 "HH":6800 BM[1:0] "LH":S9 "LL":S8
15	BM1		
16	VDD	Power	VDD supplies for display data RAM and digital logic.
17	VSS	Ground	Ground. Connect VSS and VSS2 to the shared GND pin.
18	VB1+	Power	LCD Bias Voltage. These are the voltage sources to provide SEG driving currents. These voltages are generated internally. Connect capacitors of C <sub>BX</sub> value between VB <sub>X+</sub> and VB <sub>X-</sub> . In COG application, the resistance of these ITO traces directly affects the SEG driving strength of the resulting LCD module. Minimize these trace resistance is critical in achieving high quality image.
19	VB1-		
20	VB0-		
21	VB0+		
22	VLCD	Power	LCD Power Supply.
23~24	B C	Power	Backlight Cathode (K-)
25~26	B A	Power	Backlight Anode (A+)

MODEL

GY1206120498FSWCQ01

6/20

PRODUCT SPECIFICATIONS

REV: C



## 7. AC CHARACTERISTICS

### 7-1. Parallel Bus Timing Characteristics (for 8080 MCU)

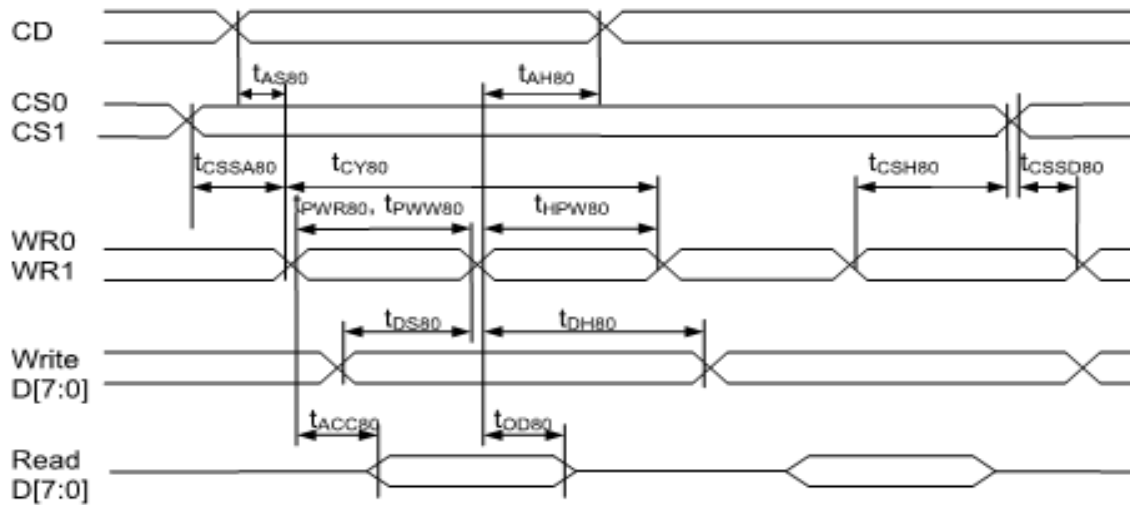

( $2.5V \leq V_{DD} < 3.3V$ ,  $T_a = -30$  to  $+85^\circ C$ )

Symbol	Signal	Description	Condition	Min.	Max.	Units
$t_{AS80}$	CD	Address setup time		0	–	nS
$t_{AH80}$	CD	Address hold time		40	–	nS
$t_{CY80}$		System cycle time		135	–	nS
$t_{PWR80}$	WR1	Pulse width (read)		65	–	nS
$t_{PWW80}$	WR0	Pulse width (write)		65	–	nS
$t_{HPW80}$	WR0, WR1	High pulse width		65	–	nS
$t_{DS80}$	D0–D7	Data setup time		30	–	nS
$t_{DH80}$	D0–D7	Data hold time		20	–	nS
$t_{ACC80}$		Read access time	$C_L = 100pF$	–	50	nS
$t_{OD80}$		Output disable time		10	50	nS
$t_{CSSA80}$	CS1/CS0	Chip select setup time		10		nS
$t_{CSSD80}$				10		nS
$t_{CSH80}$				20		nS

## 7. AC CHARACTERISTICS (Continued)

### 7-2. Parallel Bus Timing Characteristics (for 6800 MCU)

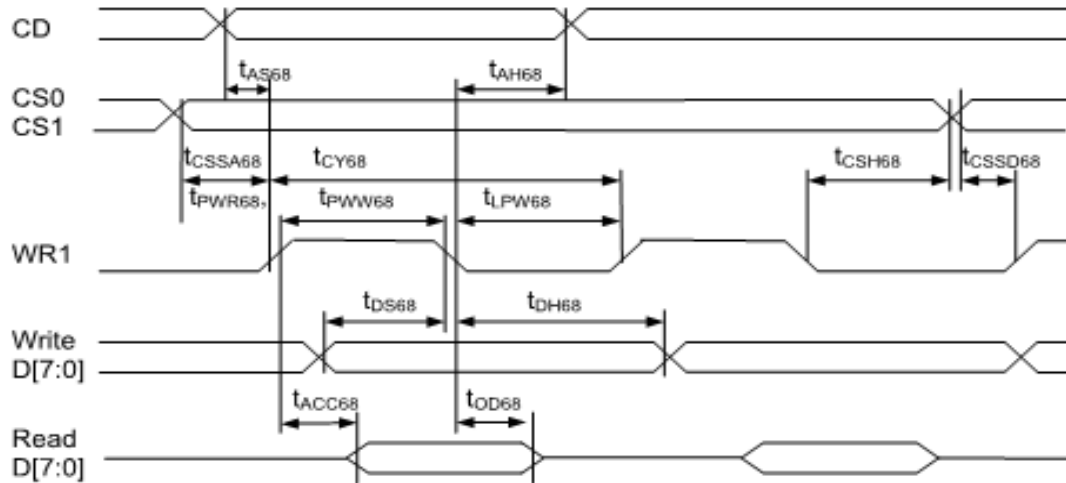

( $2.5V \leq V_{DD} < 3.3V$ ,  $T_a = -30$  to  $+85^\circ C$ )

Symbol	Signal	Description	Condition	Min.	Max.	Units
$t_{AS68}$	CD	Address setup time		0	–	nS
$t_{AH68}$		Address hold time		40	–	nS
$t_{CY68}$		System cycle time		135	–	nS
$t_{PWR68}$	WR1	Pulse width (read)		65	–	nS
$t_{PWW68}$		Pulse width (write)		65	–	nS
$t_{LPW68}$		Low pulse width		65	–	nS
$t_{DS68}$	D0~D7	Data setup time		30	–	nS
$t_{DH68}$		Data hold time		15	–	nS
$t_{ACC68}$		Read access time	$C_L = 100pF$	–	50	nS
$t_{OD68}$		Output disable time		10	50	nS
$T_{CSSA68}$	CS1/CS0	Chip select setup time		10		nS
$T_{CSSD68}$				10		nS
$T_{CSH68}$				20		nS

## 7. AC CHARACTERISTICS (Continued)

### 7-3. Serial Bus Timing Characteristics (for S8)

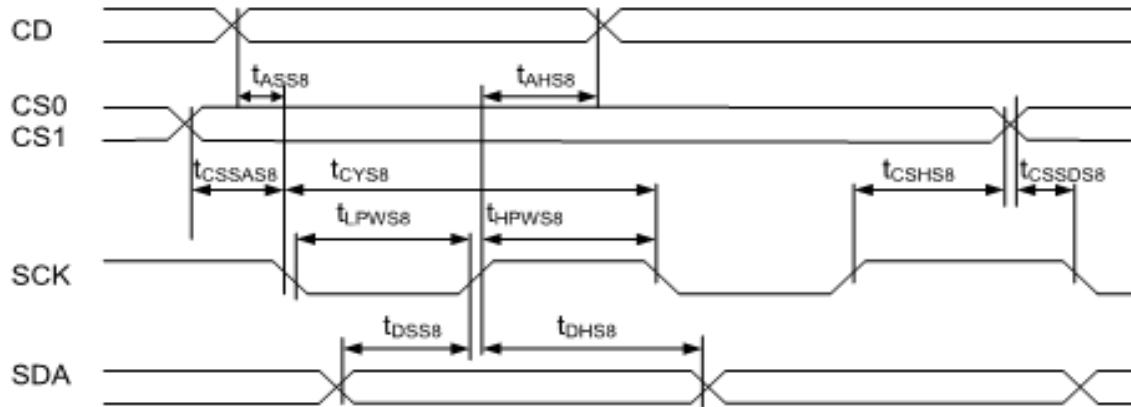

( $2.5V \leq V_{DD} < 3.3V$ ,  $T_a = -30$  to  $+85^\circ C$ )

Symbol	Signal	Description	Condition	Min.	Max.	Units
$t_{ASS8}$	CD	Address setup time		0	—	nS
$t_{AHS8}$		Address hold time		40	—	nS
$t_{CYS8}$	SCK	System cycle time		135	—	nS
$t_{LPWS8}$		Low pulse width		65	—	nS
$t_{HPWS8}$		High pulse width		65	—	nS
$t_{DSS8}$	SDA	Data setup time		30	—	nS
$t_{DHS8}$		Data hold time		15	—	nS
$t_{CSSAS8}$	CS1/CS0	Chip select setup time		10		nS
$t_{CSSDS8}$				10		
$t_{CSHS8}$				20		

## 7. AC CHARACTERISTICS (Continued)

### 7-4. Serial Bus Timing Characteristics (for S9)

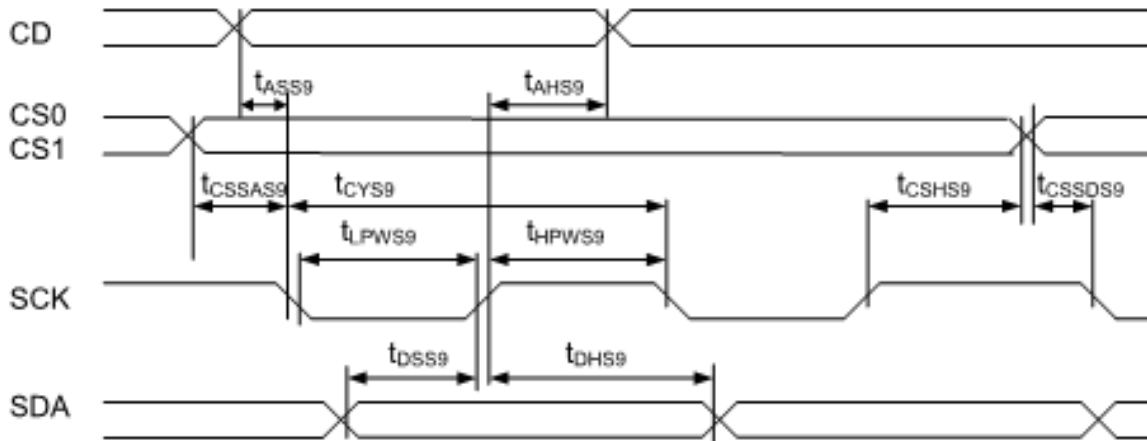

( $2.5V \leq V_{DD} < 3.3V$ ,  $T_a = -30$  to  $+85^\circ C$ )

Symbol	Signal	Description	Condition	Min.	Max.	Units
$t_{ASS9}$	CD	Address setup time		0	—	nS
$t_{AHS9}$		Address hold time		40	—	nS
$t_{CYS9}$	SCK	System cycle time		135	—	nS
$t_{LPWS9}$		Low pulse width		65	—	nS
$t_{HPWS9}$		High pulse width		65	—	nS
$t_{DSS9}$	SDA	Data setup time		30	—	nS
$t_{DHS9}$		Data hold time		15	—	nS
$t_{CSSAS9}$	CS1/CS0	Chip select setup time		10		nS
$t_{CSSDS9}$				10		
$t_{CSHS9}$				20		

## 8. INSTRUCTION DESCRIPTION

The following is a list of host commands support by UC1061

C/D: 0: Control, 1: Data

W/R: 0: Write Cycle, 1: Read Cycle

# Useful Data bits

-Don't Care

	Command	C/D	W/R	D7	D6	D5	D4	D3	D2	D1	D0	Action	Default
1	Write Data Byte	1	0	#	#	#	#	#	#	#	#	Write 1 byte	N/A
2	Read Data Byte	1	1	#	#	#	#	#	#	#	#	Read 1 byte	N/A
3	Get Status	0	1	-	MX	MY	RS	WA	DE	-	-	N/A	
4	Set Column Address LSB	0	0	0	0	0	0	#	#	#	#	Set CA [3:0]	0
	Set Column Address MSB	0	0	0	0	0	1	#	#	#	#	Set CA [7:4]	0
5	Set Multiplexing Rate	0	0	0	0	1	0	0	0	#	#	Set MR [1:0]	11b: 65
6	Set Temp. Compensation	0	0	0	0	1	0	0	1	#	#	Set TC[1:0]	00b: -0.05%/°C
7	Set Panel Loading	0	0	0	0	1	0	1	0	0	#	Set PC[0]	0b: < 15nF
8	Set Pump Control	0	0	0	0	1	0	1	1	#	#	Set PC[2:1]	11b
9	Set Adv. Program Control (double byte command)	0	0	0	0	1	1	0	0	0	R	Set APC[R][7:0], R = 0, or 1	N/A
10	Set Scroll Line	0	0	0	1	#	#	#	#	#	#	Set SL[5:0]	0
11	Set Page Address	0	0	1	0	1	1	#	#	#	#	Set PA[3:0]	0
12	Set V <sub>Bias</sub> Potentiometer (double-byte command)	0	0	1	0	0	0	0	0	0	1	Set PM[7:0]	COH
13	Set RAM Address Control	0	0	1	0	0	0	1	#	#	#	Set AC[2:0]	001b
14	Set Frame Rate	0	0	1	0	1	0	0	0	0	#	Set LC[3]	0b
15	Set All-Pixel-ON	0	0	1	0	1	0	0	1	0	#	Set DC[1]	0
16	Set Inverse Display	0	0	1	0	1	0	0	1	1	#	Set DC[0]	0
17	Set Display Enable	0	0	1	0	1	0	1	1	1	#	Set DC[2]	0
18	Set LCD Mapping Control	0	0	1	1	0	0	0	#	#	0	Set LC[2:1]	0
19	System Reset	0	0	1	1	1	0	0	0	1	0	System Reset	N/A
20	NOP	0	0	1	1	1	0	0	0	1	1	No operation	N/A
21	Set Test Control (double byte command)	0	0	1	1	1	0	0	1	TT	TT	For testing only. Do not use.	N/A
22	Set LCD Bias Ratio	0	0	1	1	1	0	1	0	#	#	Set BR[1:0]	11b: 9
23	Reset Cursor Update Mode	0	0	1	1	1	0	1	1	1	0	AC[3]=0, CA=CR	N/A
24	Set Cursor Update Mode	0	0	1	1	1	0	1	1	1	1	AC[3]=1, CR=CA	N/A

\* Other than commands listed above, all other bit patterns result in NOP (No operation).

MODEL	GY1206120498FSWCQ01	11/20	PRODUCT SPECIFICATIONS	REV: C
-------	---------------------	-------	------------------------	--------

## 9. QUALITY SPECIFICATIONS

### 9 - 1. LCM Appearance and Electric inspection Condition

1. Inspection will be done by placing LCM 30cm away from inspector's eyeballs under normal illumination.

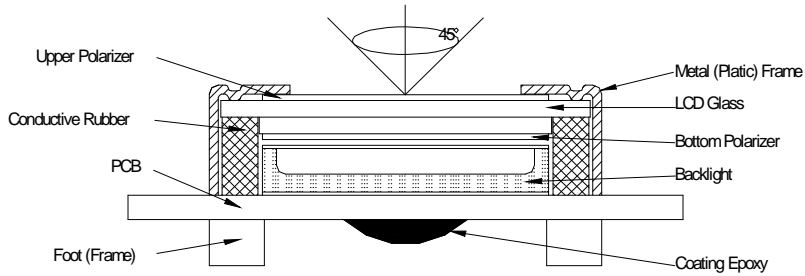

2. View Angle: with in 45° around perpendicular line.

### 9 - 2. Definition

#### 1. COB

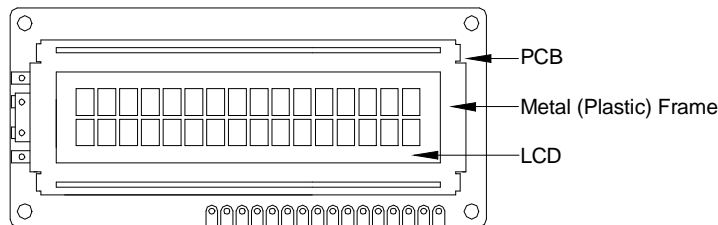

#### 2. Heat Seal

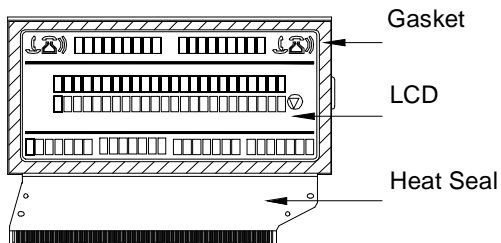

#### 3. TAB and COG

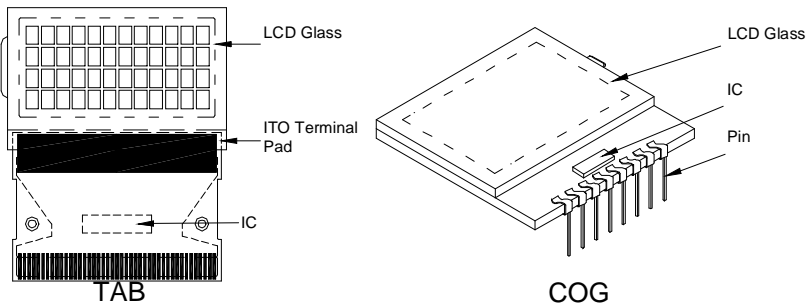

MODEL

GY1206120498FSWCQ01

12/20

PRODUCT SPECIFICATIONS

REV: C

## 9. QUALITY SPECIFICATIONS (Continued)

### 9-3. Sampling Plan and Acceptance

#### 1. Sampling Plan

MIL - STD - 105E ( || ) ordinary single inspection is used.

#### 2. Acceptance

Major defect: AQL = 0.25

Minor defect: AQL = 0.65

### 9-4. Criteria

#### 1. COB

Defect	Inspection Item	Inspection Standards	
Major	PCB copper flakes peeling off	Any copper flake in viewing Area should be greater than 1.0mm <sup>2</sup>	Reject
Major	Height of coating epoxy	Exceed the dimension of drawing	Reject
Major	Void or hole of coating epoxy	Expose bonding wire or IC	Reject
Major	PCB cutting defect	Exceed the dimension of drawing	Reject

#### 2. SMT

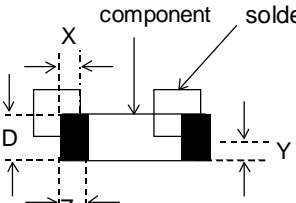
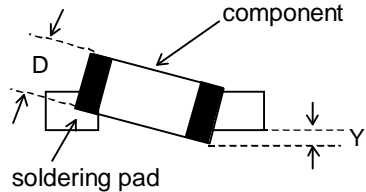
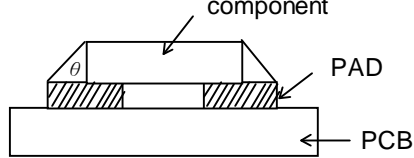
Defect	Inspection Item	Inspection Standards	
Minor	Component marking not readable		Reject
Minor	Component height	Exceed the dimension Of drawing	Reject
Major	Component solder defect (missing, extra, wrong component or wrong orientation)		Reject
Minor	Component position shift 	$X < 3/4Z$ $Y > 1/3D$	Reject Reject
Minor	Component tilt 	$Y > 1/3D$	Reject
Minor	Insufficient solder 	$\theta \leq 20^\circ$	Reject

MODEL

GY1206120498FSWCQ01

13/20

PRODUCT SPECIFICATIONS

REV: C

### 9. QUALITY SECIFICATIONS (Continued)

#### 9-4. Criteria (Continued)

##### 3. Metal (Plastic) Frame

Defect	Inspection Item	Inspection Standards		
Major	Crack / breakage	Anywhere		Reject
Minor	Frame Scratch	W	L	Acceptable of Scratch
		$w < 0.03\text{mm}$	Any	Ignore
		$0.03\text{mm} \leq w < 0.05\text{mm}$	$L \leq 5.0\text{mm}$	2
		$0.05\text{mm} \leq w < 0.1\text{mm}$	$L \leq 3.0\text{mm}$	1
		$w \geq 0.1\text{mm}$	Any	0
		Note: 1. Above criteria applicable to scratch lines with distance greater than 5mm. 2. Scratch on the back side of frame (not visible) can be ignored.		
Minor	Frame Dent, Prick $\Phi = \frac{L + W}{2}$			Acceptable of Dents / Pricks
		$\Phi \leq 1.0\text{mm}$		2
		$1.0 < \Phi \leq 1.5\text{mm}$		1
		$1.5\text{mm} > \Phi$		0
		Note: 1. Above criteria applicable to any two dents / pricks with distance greater than 5mm 2. Dent / prick on the back side of frame (not visible) can be ignored		
Minor	Frame Deformation	Exceed the dimension of drawing		
Minor	Metal Frame Oxidation	Any rust		

##### 4. Flexible Film Connector (FFC)

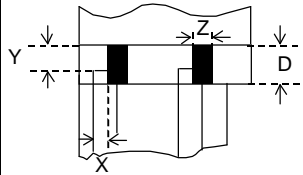
Defect	Inspection Item	Inspection Standards		
Minor	Tilted soldering	Within the angle $\pm 3^\circ$		Acceptable
Minor	Uneven solder joint /bump			Reject
Minor	Hole $\Phi = \frac{L + W}{2}$	Expose the conductive line		Reject
		$\Phi > 1.0\text{mm}$		Reject
Minor	Position shift 	$Y > 1/3D$		Reject
		$X > 1/2Z$		Reject

MODEL

GY1206120498FSWCQ01

14/20

PRODUCT SPECIFICATIONS

REV: C



## 9. QUALITY SPECIFICATIONS (Continued)

### 9-4. Criteria (Continued)

#### 5. Screw

Defect	Inspection Item	Inspection Standards	
Major	Screw missing/loosen		Reject
Minor	Screw oxidation	Any rust	Reject
Minor	Screw deformation	Difficult to accept screw driver	Reject

#### 6. Heat seal 、TCP 、FPC

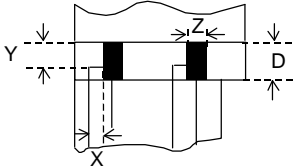
Defect	Inspection Item	Inspection Standards	
Major	Scratch expose conductive layer		Reject
Minor	HS Hole $\Phi = \frac{L+W}{2}$	$\Phi > 0.2\text{mm}$	Reject
Major	Adhesion strength	Less than the specification	Reject
Minor	Position shift 	$Y > 1/3D$	Reject
		$X > 1/2Z$	Reject
Major	Conductive line break		Reject

#### 7. LED Backing Protective Film and Others

Defect	Inspection Item	Inspection Standards	
Minor	LED dirty, prick	Acceptable number of units	
		$\Phi \leq 0.10\text{mm}$	Ignore
		$0.10 < \Phi \leq 0.15\text{mm}$	2
		$0.15 < \Phi \leq 0.2\text{mm}$	1
		$\Phi > 0.2\text{mm}$	0
		The distance between any two spots should be $\geq 10\text{mm}$ Any spot/dot/void outside of viewing area is acceptable	
Minor	Protective film tilt	Not fully cover LCD	Reject
Major	COG coating	Not fully cover ITO circuit	Reject

#### 8. Electric Inspection

Defect	Inspection Item	Inspection Standards	
Major	Short		Reject
Major	Open		Reject

MODEL

GY1206120498FSWCQ01

15/20



PRODUCT SPECIFICATIONS

REV: C

## 9. QUALITY SPECIFICATIONS (Continued)

### 9-4. Criteria (Continued)

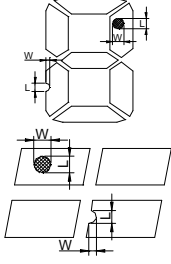
#### 9. Inspection Specification of LCD

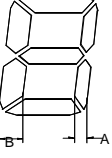
Defect	Inspect Item	Inspection Standards					
		W	$W \leq 0.03$	$0.03 < W \leq 0.05$	$W > 0.05$		
Minor	Linear Defect	* Glass Scratch * Polarizer Scratch * Fiber and Linear material	L	$L < 5$	$L < 3$	Any	
			ACC. NO.	1	1	Reject	
			Note	L is the length and W is the width of the defect			
Minor	Black Spot and Polarizer Pricked	* Foreign material between glass and polarizer or glass and glass * Polarizer hole or protuberance by external force	$\Phi$	$\Phi \leq 0.1$	$0.1 < \Phi \leq 0.15$	$0.15 < \Phi \leq 0.2$	$\Phi > 0.2$
			ACC. NO.	3EA / 1PC	2	1	0
			Note	$\Phi$ is the average diameter of the defect. Distance between two defects > 10mm.			
Minor	White Spot and Bubble in polarizer	* Unobvious transparent foreign material between glass and glass or glass and polarizer * Air protuberance between polarizer and glass	$\Phi$	$\Phi \leq 0.1$	$0.1 < \Phi \leq 0.15$	$0.15 < \Phi \leq 0.2$	$\Phi > 0.2$
			ACC. NO.	3EA / 1PC	2	1	0
			Note	$\Phi$ is the average diameter of the defect. Distance between two defects > 10mm.			
Minor	Segment Defect		$\Phi$	$\Phi \leq 0.10$	$0.10 < \Phi \leq 0.20$	$\Phi > 0.2$	
			ACC. NO.	3EA / 1PC	2	0	
			Note	W is more than 1/2 segment width		Reject	
				$\Phi = \frac{L + W}{2}$ Distance between two defect is 10mm			
Minor	Protuberant Segment	 $\Phi = (L + W) / 2$	$\Phi$	$\Phi \leq 0.10$	$0.10 < \Phi \leq 0.20$	$\Phi > 0.2$	
			W	Glue	$W \leq 1/2 \text{ Seg}$ , $W \leq 0.2$	Ignore	
			ACC. NO.	3EA / 1PC	2	0	
Minor	Assembly Mis-alignment		1. Segment				
			B	$B \leq 0.4\text{mm}$	$0.4 < B \leq 1.0\text{mm}$	$B > 1.0\text{mm}$	
			B-A	$B-A < 1/2B$	$B-A < 0.2$	$B-A < 0.25$	
			Judge	Acceptable	Acceptable	Acceptable	
			2. Dot Matrix				
	Deformation > 0.35mm			Reject			
Minor	Stain on LCD Panel Surface		Accept when stains can be wiped lightly with a soft cloth or a similar one. Otherwise, judged according to the above items: "Black spot" and "White Spot"				

MODEL

GY1206120498FSWCQ01

16/20

PRODUCT SPECIFICATIONS

REV: C

## 10. RELIABILITY

NO.	Item	Condition	Criterion
1	High Temperature Operating	70°C, 96Hrs	No defect in cosmetic and operational function allowable.
2	Low Temperature Operating	-20°C, 96Hrs	
3	High Humidity	60°C, 90%RH, 96Hrs	
4	High Temperature Storage	80°C, 96Hrs	
5	Low Temperature Storage	-30°C, 96Hrs	
6	Vibration	Random wave 10 ~ 100Hz Acceleration: 2G 60 Minute	Total current Consumption should be below double of initial value.
7	Thermal Shock	-10°C to 25°C to 60°C (60Min) (15Min) (60Min) 10Cycles	
8	ESD Testing	Contract Discharge Voltage: +1 ~ 5kV and -1 ~ -5kV  Air Discharge Voltage: +1 ~ 8kV and -1 ~ -8kV	There will be discharged ten times at every discharging voltage cycle. The voltage gap is 1kV.

- Note:
- 1) Above conditions are suitable for GOLDENTEK standard products.
  - 2) For restrict products, the test conditions listed as above must be revised.

MODEL

GY1206120498FSWCQ01

17/20

PRODUCT SPECIFICATIONS

REV: C

## 11. HANDLING PRECAUTIONS

### (1) Mounting Method

The panel of the LCD Module consists of two thin glass plates with polarizers which easily get damaged since the Module is fixed by utilizing fitting holes in the printed circuit board. Extreme care should be taken when handling the LCD Modules.

### (2) Caution of LCD handling & cleaning

When cleaning the display surface, use soft cloth with solvent (recommended below) and wipe lightly.

- Isopropyl alcohol
- Ethyl alcohol
- Trichlorotrifluoroethane

Do not wipe the display surface with dry or hard materials that will damage the polarizer surface.

Do not use the following solvent:

- Water
- Ketone
- Aromatics

### (3) Caution against static charge

The LCD Module use C-MOS LSI drivers, so we recommend that you connect any unused input terminal to  $V_{DD}$  or  $V_{SS}$ , do not input any signals before power is turned on. And ground your body, Work/assembly table. And assembly equipment to protect against static electricity.

### (4) Packaging

- Modules use LCD elements, and must be treated as such. Avoid intense shock and falls from a height.
- To prevent modules from degradation. Do not operate or store them exposed directly to sunshine or high temperature/humidity.

### (5) Caution for operation

- It is indispensable to drive LCD's within the specified voltage limit since the higher voltage than the limit shorten LCD life. An electrochemical reaction due to direct current causes LCD deterioration, Avoid the use of direct current drive.

**MODEL**

**GY1206120498FSWCQ01**

**18/20**

**PRODUCT SPECIFICATIONS**

**REV: C**

## 11. HANDLING PRECAUTIONS (Continued)

- Response time will be extremely delayed at lower temperature than the operating temperature range and on the other hand at higher temperature LCD's show dark color in them.

However those phenomena do not mean malfunction or out of order with LCD's.

Which will come back in the specified operating temperature range.

- If the display area is pushed hard during operation, some font will be abnormally displayed but it resumes normal condition after turning off once.
- A slight dew depositing on terminals is a cause for electro-chemical reaction resulting in terminal open circuit.

Usage under the relative condition of 40°C, 80%RH or less is required.

### (6) Storage

In the case of storing for a long period of time (for instance ,for years) for the purpose or replacement use, The following ways are recommended.

- Storage in a polyethylene bag with sealed so as not to enter fresh air outside in it, And with no desiccant.
- Placing in a dark place where neither exposure to direct sunlight nor light is. Keeping temperature in the specified storage temperature range.
- Storing with no touch on polarizer surface by the anything else. (It is recommended to store them as they have been contained in the inner container at the time of delivery)

### (7) Safety

- It is recommendable to crash damaged or unnecessary LCD into pieces and wash off liquid crystal by using solvents such as acetone and ethanol.

Which should be burned up later.

- When any liquid crystal leaked out of a damaged glass cell comes in contact with your hands, please wash it off well with soap and water.

MODEL

GY1206120498FSWCQ01

19/20

PRODUCT SPECIFICATIONS

REV: C

## 12. OUTLINE DIMENSION

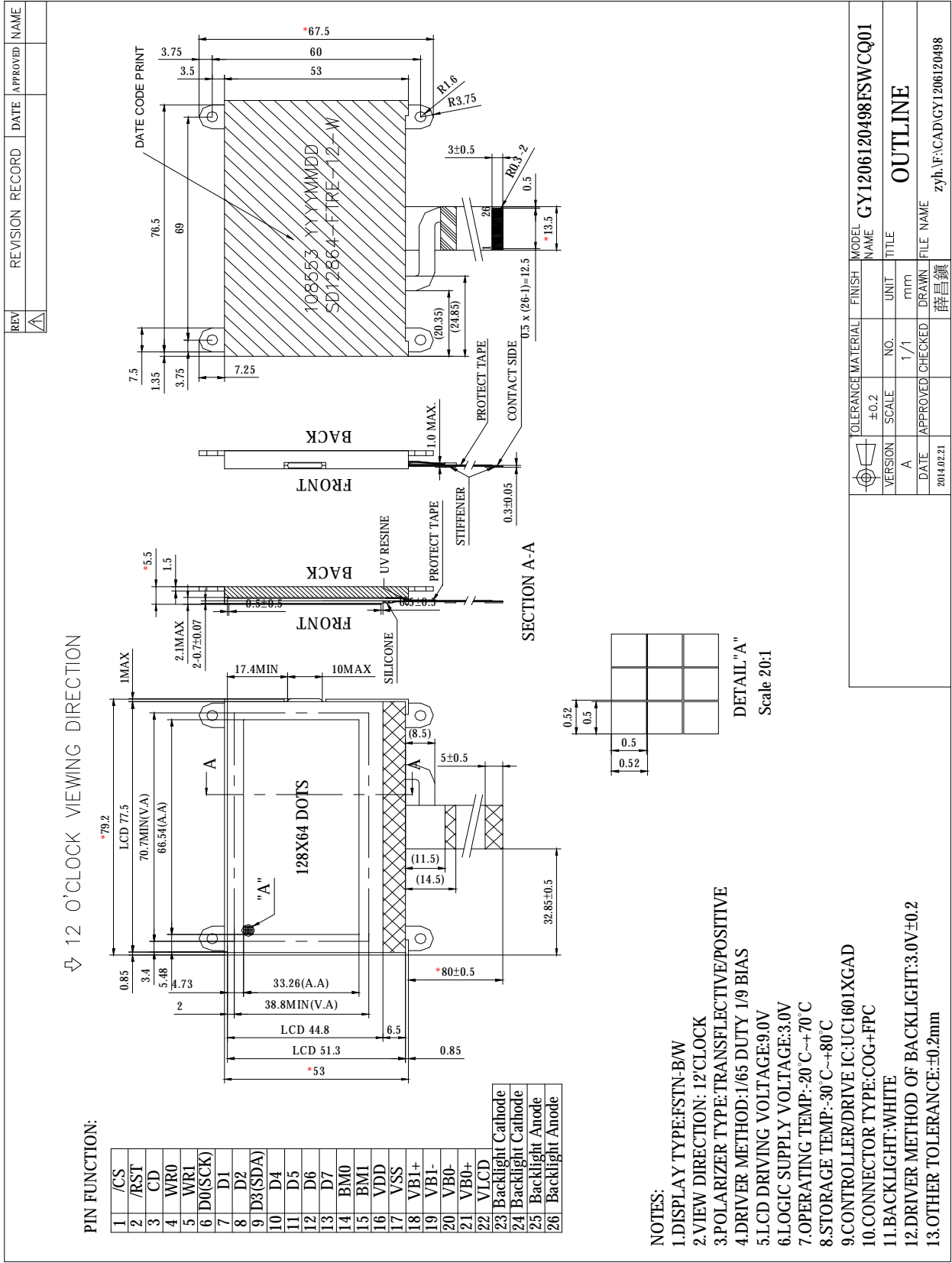

TOLERANCE MATERIAL	FINISH	MODEL NAME	GY1206120498FSWCQ01
±0.2		TITLE	OUTLINE
VERSION	NO.	UNIT	mm
A	1/1	DRAWN	薛昌镇
DATE	APPROVED	CHECKED	FILE NAME
20140221			zyh.Y:\CAD\GY1206120498

# SAMPLE OUTGOING INSPECTION REPORT (LCM)

Data: 2014/02/24

NO. : QAD08007

Customer	Product NO.	Driving Voltage	Testing Condition	Quantity
Swissdis AG	GY1206120498FSWCQ01	VOP=9.0V	25°C	10 Pcs

### Inspection Result

Items	Specification
Display Mode	<input checked="" type="radio"/> W / B Mode <input type="radio"/> B / W Mode <input type="radio"/> Yellow Mode <input type="radio"/> Blue Mode <input type="radio"/> Gray Mode
Polarizer Type	<input type="radio"/> Reflective <input checked="" type="radio"/> Transflective <input type="radio"/> Transmissive
Viewing direction	<input type="radio"/> 3 O'clock <input type="radio"/> 6 O'clock <input type="radio"/> 9 O'clock <input checked="" type="radio"/> 12 O'clock

### Electrical / Appearance

Item	Inspection Method	Specification	Inspection Result	
Appearance	Spot Gauge Caliper	Final Inspection Criteria	<input checked="" type="radio"/> OK	<input type="radio"/> NG
Electrical	LCM Tester	Product Specification	<input checked="" type="radio"/> OK	<input type="radio"/> NG
Pattern	LCM Tester	Drawing	<input checked="" type="radio"/> OK	<input type="radio"/> NG

### Dimension / Supply Current

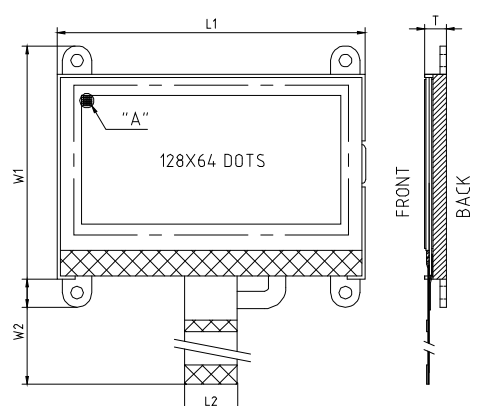
Item	Spec.(mm)	NO.1	NO.2	NO.3	NO.4	NO.5	Result		Fig.
							<input checked="" type="radio"/> OK	<input type="radio"/> NG	
L1	79.2±0.2	79.12	79.13	79.09	79.10	79.08	<input checked="" type="radio"/> OK	<input type="radio"/> NG	
L2	13.5±0.2	13.46	13.48	13.47	13.48	13.53	<input checked="" type="radio"/> OK	<input type="radio"/> NG	
W1	67.5±0.2	67.33	67.36	67.35	67.38	67.40	<input checked="" type="radio"/> OK	<input type="radio"/> NG	
W2	80±0.5	79.98	79.90	79.80	79.93	79.86	<input checked="" type="radio"/> OK	<input type="radio"/> NG	
T	5.5±0.2	5.47	5.47	5.47	5.48	5.49	<input checked="" type="radio"/> OK	<input type="radio"/> NG	
IDD	2.0mA(max)	0.80	0.80	0.80	0.80	0.80	<input checked="" type="radio"/> OK	<input type="radio"/> NG	

<b>Designed</b>	Joan	<b>Checked</b>	/	<b>Approved</b>	Wallace
-----------------	------	----------------	---	-----------------	---------

## **Attached File: Initial code**

```
ComWrite(0x26);    //Set temp. compensation
ComWrite(0xc4);    // Set LCD mapping control
ComWrite(0x0eb);   // Set LCD bias
ComWrite(0x88);    // set RAM address control
ComWrite(0x81);    // Set gain and potentiometer (Double Byte Command)
ComWrite(0x65);    // Set reference voltage register
ComWrite(0x2f);    // Set Pump Control: internal  VLCD
```